

The logo consists of the letters 'MXI' in a bold, serif font, oriented vertically within a rectangular frame.

# MXI-2 Configuration Reference Manual

September 1997 Edition  
Part Number 321713A-01

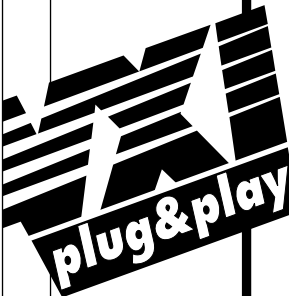



### **Internet Support**

support@natinst.com

E-mail: info@natinst.com

FTP Site: ftp.natinst.com

Web Address: <http://www.natinst.com>



### **Bulletin Board Support**

BBS United States: (512) 794-5422

BBS United Kingdom: 01635 551422

BBS France: 01 48 65 15 59



### **Fax-on-Demand Support**

(512) 418-1111

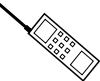

### **Telephone Support (U.S.)**

Tel: (512) 795-8248

Fax: (512) 794-5678



### **International Offices**

Australia 03 9879 5166, Austria 0662 45 79 90 0, Belgium 02 757 00 20,  
Canada (Ontario) 905 785 0085, Canada (Québec) 514 694 8521, Denmark 45 76 26 00,  
Finland 09 725 725 11, France 01 48 14 24 24, Germany 089 741 31 30,  
Hong Kong 2645 3186, Israel 03 5734815, Italy 02 413091, Japan 03 5472 2970,  
Korea 02 596 7456, Mexico 5 520 2635, Netherlands 0348 433466, Norway 32 84 84 00,  
Singapore 2265886, Spain 91 640 0085, Sweden 08 730 49 70, Switzerland 056 200 51 51,  
Taiwan 02 377 1200, United Kingdom 01635 523545

### **National Instruments Corporate Headquarters**

6504 Bridge Point Parkway Austin, TX 78730-5039 Tel: (512) 794-0100

# Important Information

---

## Warranty

The National Instruments MXIbus boards and accessories are warranted against defects in materials and workmanship for a period of one year from the date of shipment, as evidenced by receipts or other documentation. National Instruments will, at its option, repair or replace equipment that proves to be defective during the warranty period. This warranty includes parts and labor.

The media on which you receive National Instruments software are warranted not to fail to execute programming instructions, due to defects in materials and workmanship, for a period of 90 days from date of shipment, as evidenced by receipts or other documentation. National Instruments will, at its option, repair or replace software media that do not execute programming instructions if National Instruments receives notice of such defects during the warranty period. National Instruments does not warrant that the operation of the software shall be uninterrupted or error free.

A Return Material Authorization (RMA) number must be obtained from the factory and clearly marked on the outside of the package before any equipment will be accepted for warranty work. National Instruments will pay the shipping costs of returning to the owner parts which are covered by warranty.

National Instruments believes that the information in this manual is accurate. The document has been carefully reviewed for technical accuracy. In the event that technical or typographical errors exist, National Instruments reserves the right to make changes to subsequent editions of this document without prior notice to holders of this edition. The reader should consult National Instruments if errors are suspected. In no event shall National Instruments be liable for any damages arising out of or related to this document or the information contained in it.

EXCEPT AS SPECIFIED HEREIN, NATIONAL INSTRUMENTS MAKES NO WARRANTIES, EXPRESS OR IMPLIED, AND SPECIFICALLY DISCLAIMS ANY WARRANTY OF MERCHANTABILITY OR FITNESS FOR A PARTICULAR PURPOSE. CUSTOMER'S RIGHT TO RECOVER DAMAGES CAUSED BY FAULT OR NEGLIGENCE ON THE PART OF NATIONAL INSTRUMENTS SHALL BE LIMITED TO THE AMOUNT THEREFORE PAID BY THE CUSTOMER. NATIONAL INSTRUMENTS WILL NOT BE LIABLE FOR DAMAGES RESULTING FROM LOSS OF DATA, PROFITS, USE OF PRODUCTS, OR INCIDENTAL OR CONSEQUENTIAL DAMAGES, EVEN IF ADVISED OF THE POSSIBILITY THEREOF. This limitation of the liability of National Instruments will apply regardless of the form of action, whether in contract or tort, including negligence. Any action against National Instruments must be brought within one year after the cause of action accrues. National Instruments shall not be liable for any delay in performance due to causes beyond its reasonable control. The warranty provided herein does not cover damages, defects, malfunctions, or service failures caused by owner's failure to follow the National Instruments installation, operation, or maintenance instructions; owner's modification of the product; owner's abuse, misuse, or negligent acts; and power failure or surges, fire, flood, accident, actions of third parties, or other events outside reasonable control.

## Copyright

Under the copyright laws, this publication may not be reproduced or transmitted in any form, electronic or mechanical, including photocopying, recording, storing in an information retrieval system, or translating, in whole or in part, without the prior written consent of National Instruments Corporation.

## Trademarks

LabVIEW®, CVI™, MANTIS™, MITE™, NI-VISA™, NI-VXI™, and PXI™ are trademarks of National Instruments Corporation.

Product and company names listed are trademarks or trade names of their respective companies.

## WARNING REGARDING MEDICAL AND CLINICAL USE OF NATIONAL INSTRUMENTS PRODUCTS

National Instruments products are not designed with components and testing intended to ensure a level of reliability suitable for use in treatment and diagnosis of humans. Applications of National Instruments products involving medical or clinical treatment can create a potential for accidental injury caused by product failure, or by errors on the part of the user or application designer. Any use or application of National Instruments products for or involving medical or clinical treatment must be performed by properly trained and qualified medical personnel, and all traditional medical safeguards, equipment, and procedures that are appropriate in the particular situation to prevent serious injury or death should always continue to be used when National Instruments products are being used. National Instruments products are NOT intended to be a substitute for any form of established process, procedure, or equipment used to monitor or safeguard human health and safety in medical or clinical treatment.

# FCC/DOC Radio Frequency Interference Class A Compliance

---

This equipment generates and uses radio frequency energy and, if not installed and used in strict accordance with the instructions in this manual, may cause interference to radio and television reception. Classification requirements are the same for the Federal Communications Commission (FCC) and the Canadian Department of Communications (DOC). This equipment has been tested and found to comply with the following two regulatory agencies:

## Federal Communications Commission

This equipment has been tested and found to comply with the limits for a Class A digital device, pursuant to part 15 of the FCC Rules. These limits are designed to provide reasonable protection against harmful interference when the equipment is operated in a commercial environment. This equipment generates, uses, and can radiate radio frequency energy and, if not installed and used in accordance with the instruction manual, may cause harmful interference to radio communications. Operation of this equipment in a residential area is likely to cause harmful interference in which case the user will be required to correct the interference at his own expense.

**Notices to User:** *Changes or modifications not expressly approved by National Instruments could void the user's authority to operate the equipment under the FCC Rules.*

*This device complies with the FCC rules only if used with shielded interface cables of suitable quality and construction. National Instruments used such cables to test this device and provides them for sale to the user. The use of inferior or nonshielded interface cables could void the user's authority to operate the equipment under the FCC rules.*

If necessary, consult National Instruments or an experienced radio/television technician for additional suggestions. The following booklet prepared by the FCC may also be helpful: *Interference to Home Electronic Entertainment Equipment Handbook*. This booklet is available from the U.S. Government Printing Office, Washington, DC 20402.

## Canadian Department of Communications

This Class A digital apparatus meets all requirements of the Canadian Interference-Causing Equipment Regulations.

Cet appareil numérique de la classe A respecte toutes les exigences du Règlement sur le matériel brouilleur du Canada.



*Table  
of  
Contents*

---

## About This Manual

Organization of This Manual .....	ix
Conventions Used in This Manual .....	x
How to Use This Documentation Set .....	x
Related Documentation .....	xi
Customer Communication .....	xii

## Chapter 1

### Introduction

How to Use This Manual .....	1-1
MXI-2 Description .....	1-2
MXI-2 Interface Kit Overview .....	1-2
Hardware Description .....	1-3

## Chapter 2

### PCI-MXI-2 Configuration and Installation

Configure the PCI-MXI-2 .....	2-1
Configuration EEPROM .....	2-3
Onboard DRAM .....	2-3
Install the PCI-MXI-2 .....	2-4

## Chapter 3

### PXI-8320 Configuration and Installation

Configure the PXI-8320 .....	3-1
Configuration EEPROM .....	3-2
Onboard DRAM .....	3-2
Install the PXI-8320 .....	3-3

## Chapter 4

### VXI-MXI-2 Configuration and Installation

Configure the VXI-MXI-2 .....	4-1
Front Panel Features.....	4-3
Removing the Metal Enclosure.....	4-3
VXIbus Logical Address.....	4-3
VXIbus Slot 0/Non-Slot 0.....	4-5
VXIbus CLK10 Routing.....	4-6
Trigger Input Termination .....	4-10
MXIbus Termination.....	4-11
Configuration EEPROM.....	4-12
Onboard DRAM.....	4-14
VXIbus Local Bus.....	4-16
Install the VXI-MXI-2.....	4-18
Connect the MXIbus Cable .....	4-19

## Chapter 5

### VXI-MXI-2/B Configuration and Installation

Configure the VXI-MXI-2/B.....	5-1
Front Panel Features.....	5-3
VXIbus Logical Address.....	5-3
VXIbus Slot 0/Non-Slot 0.....	5-4
VXIbus CLK10 Routing.....	5-6
Trigger Input Termination .....	5-9
MXIbus Termination.....	5-9
Configuration EEPROM.....	5-11
Onboard DRAM.....	5-12
VXIbus Local Bus.....	5-14
Install the VXI-MXI-2/B.....	5-15
Connect the MXIbus Cable .....	5-16

## Chapter 6

### VME-MXI-2 Configuration and Installation

Configure the VME-MXI-2.....	6-1
Front Panel Features.....	6-3
VMEbus A16 Base Address .....	6-3
MXIbus Termination.....	6-4
Configuration EEPROM.....	6-5
Onboard DRAM.....	6-7
VME-MXI-2 Intermodule Signaling .....	6-9

Install the VME-MXI-2 .....	6-10
Connect the MXIbus Cable.....	6-11

## Appendix A Specifications

## Appendix B EEPROM Configuration

## Appendix C National Instruments Software Choices

## Appendix D Customer Communication

## Glossary

## Index

## Figures

Figure 2-1. PCI-MXI-2 Parts Locator Diagram .....	2-2
Figure 2-2. Installing the PCI-MXI-2 in a Computer.....	2-5
Figure 3-1. PXI-8320 Parts Locator Diagram .....	3-2
Figure 3-2. Installing the PXI-8320 in a PXI Chassis .....	3-4
Figure 4-1. VXI-MXI-2 Right-Side Cover.....	4-2
Figure 4-2. Logical Address Selection .....	4-5
Figure 4-3. VXIbus Slot Configuration.....	4-6
Figure 4-4. VXIbus CLK10 Routing.....	4-7
Figure 4-5. SMB CLK10 Settings .....	4-9
Figure 4-6. Receiving or Driving MXIbus CLK10 .....	4-10
Figure 4-7. SMB Trigger Input Termination.....	4-11
Figure 4-8. MXIbus Termination .....	4-12
Figure 4-9. EEPROM Operation .....	4-14
Figure 4-10. SIMM Size Configuration .....	4-15
Figure 4-11. VXIbus Local Bus Configuration.....	4-17
Figure 4-12. MXI-2 Cable Configuration Using a PCI-MXI-2 and a VXI-MXI-2 ...	4-20

Figure 5-1.	VXI-MXI-2/B Parts Locator Diagram .....	5-2
Figure 5-2.	Logical Address Selection .....	5-4
Figure 5-3.	VXIbus Slot Configuration .....	5-5
Figure 5-4.	VXIbus CLK10 Routing .....	5-6
Figure 5-5.	SMB CLK10 Settings .....	5-8
Figure 5-6.	Receiving or Driving MXIbus CLK10.....	5-9
Figure 5-7.	SMB Trigger Input Termination .....	5-9
Figure 5-8.	MXIbus Termination .....	5-10
Figure 5-9.	EEPROM Operation.....	5-12
Figure 5-10.	SIMM Size Configuration .....	5-13
Figure 5-11.	VXIbus Local Bus Configuration.....	5-15
Figure 5-12.	MXI-2 Cable Configuration Using a PCI-MXI-2 and a VXI-MXI-2/B	5-17
Figure 6-1.	VME-MXI-2 Parts Locator Diagram .....	6-2
Figure 6-2.	Base Address Selection .....	6-4
Figure 6-3.	MXIbus Termination .....	6-5
Figure 6-4.	EEPROM Operation.....	6-7
Figure 6-5.	SIMM Size Configuration .....	6-8
Figure 6-6.	VME-MXI-2 Intermodule Signaling Settings .....	6-10
Figure 6-7.	MXI-2 Cable Configuration Using a PCI-MXI-2 and a VME-MXI-2 .	6-12
Figure B-1.	Normal EEPROM Operation on the PCI-MXI-2 .....	B-2
Figure B-2.	Normal EEPROM Operation on the PXI-8320.....	B-2
Figure B-3.	Restoring the Factory Configuration on the PCI-MXI-2 .....	B-3
Figure B-4.	Restoring the Factory Configuration on the PXI-8320 .....	B-3

## Tables

Table 2-1.	PCI-MXI-2 DRAM Configurations .....	2-3
Table 3-1.	PXI-8320 DRAM Configurations .....	3-3
Table 4-1.	VXI-MXI-2 DRAM Configurations .....	4-15
Table 5-1.	VXI-MXI-2/B DRAM Configurations.....	5-13
Table 6-1.	VME-MXI-2 DRAM Configurations.....	6-8



This manual contains instructions for installing and configuring the National Instruments MXI-2 boards. If you received your hardware as part of a kit, such as the VXI-PCI8000 interface kit, this manual is meant to be used with *Getting Started with Your PCI-Based MXI-2 Interface for Windows 95/NT*.

This manual contains hardware configuration information for the VXI-MXI-2 (C-size and B-size) and VME-MXI-2, which plug into your VXI or VME mainframe and link your computer to the VXIbus or VMEbus, respectively. This manual also describes how to set up the PCI-MXI-2 and PXI-8320 interface boards, which link your PCI-based computer or PXI/CompactPCI chassis to the MXIbus.

Because the C-size VXI-MXI-2 and the B-size VXI-MXI-2/B are functionally equivalent, this manual uses the term *VXI-MXI-2* to refer to either module unless otherwise noted.

## Organization of This Manual

---

This manual is organized as follows:

- Chapter 1, *Introduction*, introduces you to MXI-2 and your MXI-2 kit.
- Chapter 2, *PCI-MXI-2 Configuration and Installation*, contains the instructions to configure and install the PCI-MXI-2 module. This chapter applies only if your kit contains a PCI-MXI-2.
- Chapter 3, *PXI-8320 Configuration and Installation*, contains the instructions to configure and install the PXI-8320 module. This chapter applies only if your kit contains a PXI-8320.
- Chapter 4, *VXI-MXI-2 Configuration and Installation*, contains the instructions to configure and install the VXI-MXI-2 module. This chapter applies only if your kit contains a C-size VXI-MXI-2.
- Chapter 5, *VXI-MXI-2/B Configuration and Installation*, contains the instructions to configure and install the VXI-MXI-2/B module. This chapter applies only if your kit contains a B-size VXI-MXI-2.

- Chapter 6, *VME-MXI-2 Configuration and Installation*, contains the instructions to configure and install the VME-MXI-2 module. This chapter applies only if your kit contains a VME-MXI-2.
- Appendix A, *Specifications*, lists various module specifications of the PCI-MXI-2, PXI-8320, VXI-MXI-2 (C-size and B-size), and VME-MXI-2, such as physical dimensions and power requirements.
- Appendix B, *EEPROM Configuration*, describes how to control the operation of the PCI-MXI-2 or PXI-8320 onboard EEPROM and how to fix an invalid EEPROM setting.
- Appendix C, *National Instruments Software Choices*, discusses the National Instruments software available for your MXI-2 kit.
- Appendix D, *Customer Communication*, contains forms you can use to request help from National Instruments or to comment on our products and manuals.
- The *Glossary* contains an alphabetical list and description of terms used in this manual, including abbreviations, acronyms, metric prefixes, mnemonics, and symbols.
- The *Index* contains an alphabetical list of key terms and topics in this manual, including the page where you can find each one.

## Conventions Used in This Manual

---

The following conventions are used in this manual:

***bold italic***

Bold italic text denotes a note, caution, or warning.

*italic*

Italic text denotes emphasis, a cross reference, or an introduction to a key concept.

monospace

Text in this font denotes the proper names of programs, subprograms, functions, operations, and filenames.

The *Glossary* lists abbreviations, acronyms, metric prefixes, mnemonics, symbols, and terms.

## How to Use This Documentation Set

---

The *MXI-2 Configuration Reference Manual* contains information on configuring, installing, and cabling your MXI-2 hardware. You will need to use this manual in conjunction with the getting started manual.

*Getting Started with Your PCI-Based MXI-2 Interface for Windows 95/NT* contains an overview of the MXI-2 hardware and the NI-VXI/VISA software, guides you through setting up your kit, and helps you get started with application development. You can also use this manual as a reference for the hardware and software default settings and to find the answers to commonly asked questions.

When you have successfully set up your system, you can begin to develop applications in NI-VXI and/or NI-VISA. The *NI-VXI User Manual* presents the concepts of VXI and prepares you for detailed explanations of the NI-VXI functions. Study the descriptions of each function given in the online help utility to fully understand the purpose and syntax of each function.

Refer to the *NI-VISA User Manual* to learn about VISA and how to use it in your system. Online help is also available that describes the attributes, events, and operations you can use in NI-VISA.



**Note:** *You can view the NI-VXI User Manual and the NI-VISA User Manual online. Use the Acrobat Reader program, version 3.0 or later, to open and navigate through the NIVXIUM.pdf and NIVISAUM.pdf files.*

## Related Documentation

---

The following documents contain information that you may find helpful as you read this manual:

- ANSI/IEEE Standard 1014-1987, *IEEE Standard for a Versatile Backplane Bus: VMEbus*
- ANSI/IEEE Standard 1155-1993, *IEEE VMEbus Extensions for Instrumentation: VXibus*
- ANSI/VITA 1-1994, *VME64*
- *CompactPCI Specification*, Revision 2.0, PCI Industrial Computers Manufacturers Group
- *Multisystem Extension Interface Bus Specification*, Version 2.0, National Instruments Corporation
- *PCI Local Bus Specification*, Revision 2.1, PCI Special Interest Group
- *PCI-MXI-2 User Manual*, National Instruments Corporation
- *PXI-8320 User Manual*, National Instruments Corporation
- *PXI Specification*, Revision 1.0, National Instruments Corporation

- *VME-MXI-2 User Manual*, National Instruments Corporation
- *VXI-MXI-2 User Manual*, National Instruments Corporation
- *VXI-6, VXIbus Mainframe Extender Specification*, Rev. 1.0, VXIbus Consortium

## Customer Communication

---

National Instruments wants to receive your comments on our products and manuals. We are interested in the applications you develop with our products, and we want to help if you have problems with them. To make it easy for you to contact us, this manual contains comment and configuration forms for you to complete. These forms are in Appendix D, *Customer Communication*, at the end of this manual.

# Introduction

This chapter introduces you to MXI-2 and your MXI-2 kit.

## How to Use This Manual

The factory default settings for your MXI-2 hardware are suitable for most typical applications. You may need this manual only to follow the installation instructions for each board. If you want to try another configuration, use this manual for instructions on changing your hardware settings.

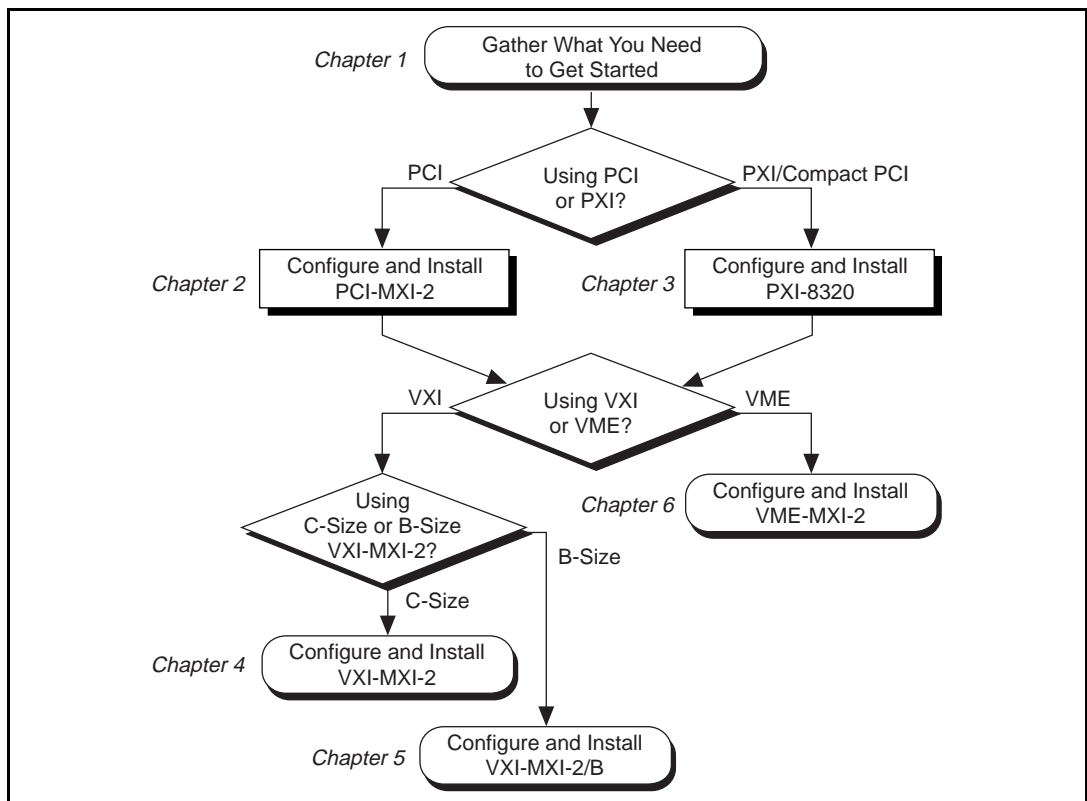

## MXI-2 Description

---

MXI-2 is the second generation of the National Instruments MXIbus product line. The MXIbus is a general-purpose, 32-bit, multimaster system bus on a cable. MXI-2 expands the number of signals on a standard MXI cable by including VXI triggers, all VXI interrupts, CLK10, and all of the utility bus signals (SYSFAIL\*, SYSRESET\*, and ACFAIL\*).

Because MXI-2 incorporates all of these new signals into a single connector, the triggers, interrupts, and utility signals can be extended not only to other mainframes but also to the local CPU in all MXI-2 products using a single cable. Thus, with MXI-2, CPU interface boards such as the PCI-MXI-2 and PXI-8320 perform as though they were plugged directly into the VXI/VME backplane.

In addition, MXI-2 boosts data throughput performance past previous-generation MXIbus products by defining new high-performance protocols. MXI-2 is a superset of MXI. All accesses initiated by MXI devices work with MXI-2 devices. However, MXI-2 defines synchronous MXI block data transfers that surpass previous block data throughput benchmarks. The new synchronous MXI block protocol increases MXI-2 throughput to a maximum of 33 MB/s between two MXI-2 devices. All National Instruments MXI-2 boards can initiate and respond to synchronous MXI block cycles.



**Note:** *In the remainder of this manual, the term MXIbus refers to MXI-2.*

## MXI-2 Interface Kit Overview

---

This manual contains separate chapters devoted to each National Instruments MXI-2 controller. When you install one MXI-2 interface device in your computer and another in your mainframe, you connect the two with a MXIbus cable. The net result is that the computer operates as though it were installed directly in the VXI/VME mainframe.

The interface kits described in this manual link a PCI-based computer or a PXI/CompactPCI chassis directly to the VXIbus or VMEbus using the high-speed Multisystem eXtension Interface bus (MXI-2). You can use these kits on a variety of platforms, including all Microsoft platforms, Macintosh, and Solaris.

The MXI-2 kits, which include a MXI-2 cable and National Instruments software, are as follows:

- VXI-PCI8000, containing a PCI-MXI-2 and a C-size or B-size VXI-MXI-2
- VXI-PXI8000, containing a PXI-8320 and a C-size or B-size VXI-MXI-2
- VME-PCI8000, containing a PCI-MXI-2 and a VME-MXI-2
- VME-PXI8000, containing a PXI-8320 and a VME-MXI-2

A PCI-based computer equipped with a VXI-PCI8000 interface, or a PXI/CompactPCI chassis equipped with a VXI-PXI8000, can function as a VXI Commander and Resource Manager. A PCI-based computer equipped with a VME-PCI8000 interface, or a PXI/CompactPCI chassis equipped with a VME-PXI8000, can function as both a VMEbus master and a slave device. The MXI-2 interface kit makes your computer behave as though it were plugged directly into the VXI/VME backplane as an embedded CPU VXI/VME module.

## Hardware Description

---

The PCI-MXI-2 is a half-size, PCI-compatible plug-in circuit board that plugs into one of the expansion slots in your PCI-based computer. The PXI-8320 is a 3U-size, PXI/CompactPCI-compatible circuit board that plugs into one of the peripheral slots in your PXI/CompactPCI chassis. Both boards link your computer directly to the MXIbus and vice versa. Because the PCI-MXI-2 and PXI-8320 use the same communication register set that other VXIbus message-based devices use, other MXIbus devices view your board as a VXIbus device. The PCI-MXI-2 and PXI-8320 can also function as the MXIbus System Controller and can terminate the MXIbus signals directly on the PCI-MXI-2 and PXI-8320. In addition, you can have up to 16 MB of onboard DRAM on your board that can be shared with the MXIbus and VXI/VMEbus and used as a dedicated data buffer.

The VXI-MXI-2 module is an extended-class, register-based VXIbus device with optional VXIbus Slot 0 capability so that it can reside in any slot in a C-size or D-size chassis.



**Note:** *D-size VXI mainframes have connections for a P3 connector. The VXI-MXI-2, however, does not have this connector and, if configured as a Slot 0 controller, cannot provide the necessary control for VXI devices that need P3 support.*

Optionally, you can use the VXI-MXI-2/B, which can reside in any B-size VXIbus slot. Although they are functionally equivalent, this manual describes the C-size and B-size VXI-MXI-2 modules in separate chapters. This is because there are some differences in how you configure the two modules. The C-size VXI-MXI-2 is housed in a metal enclosure to improve EMC performance and to provide easy handling. The B-size module does not require this enclosure.



**Note:** *Unless otherwise noted, the term VXI-MXI-2 refers to both the C-size and B-size modules.*

The VXI-MXI-2 uses address mapping to convert MXIbus cycles into VXIbus cycles and vice versa. By connecting to the PCI-MXI-2 or PXI-8320 board, the VXI-MXI-2 links the PCI bus or the PXI/CompactPCI bus to the VXIbus. The VXI-MXI-2 can automatically determine whether it is located in VXI Slot 0 and if it is the MXIbus System Controller.

The VME-MXI-2 module is a single-slot, double-height VMEbus device with optional VMEbus System Controller functions. It uses address mapping to convert MXIbus cycles into VMEbus cycles and vice versa, just like the VXI-MXI-2. By connecting to the PCI-MXI-2 or PXI-8320 board, it links the PCI bus or the PXI/CompactPCI bus to the VMEbus. The VME-MXI-2 can automatically determine if it is located in the first slot of a VMEbus chassis and if it is the MXIbus System Controller. The VME-MXI-2 requires that the VMEbus chassis comply with the VME64 protocol to be able to auto-detect Slot 1.



**Note:** *The VME-MXI-2 is not equivalent to the VXI-MXI-2/B even though their form factor is the same. The VXI-MXI-2/B provides VXI trigger, MODID, and CLK10 support, while the VME-MXI-2 does not.*

Also, the VXI-MXI-2 and VME-MXI-2 automatically terminate the MXIbus if installed as the first or last device in the MXIbus. If installed in the middle of the MXIbus, both the VXI-MXI-2 and VME-MXI-2 automatically disable MXIbus termination. In addition, you can have up to 64 MB of onboard DRAM on the VXI-MXI-2 and VME-MXI-2 modules that can either be shared with the VXI/VMEbus and MXIbus or used as a dedicated data buffer.

The MXI-2 products achieve high-performance block transfer rates by integrating the MITE custom ASIC, a sophisticated dual-channel DMA controller with standard interfaces for VXI, VME, MXI, PCI, and PXI. By using MITE DMA to transfer data and commands to and from



devices, the MITE frees up a computer's microprocessor to perform other tasks such as data analysis and presentation. In addition to DMA, the MITE incorporates both the new Synchronous MXI protocol and VME64 MBLT (8-byte block transfers in which both the address bus and data bus are used to transfer data) directly into the ASIC to perform the fastest transfers to instruments.

# PCI-MXI-2 Configuration and Installation

---

Chapter

2

This chapter contains the instructions to configure and install the PCI-MXI-2 module. This chapter applies only if your kit contains a PCI-MXI-2. If you ordered a kit containing a PXI-8320, refer to Chapter 3, *PXI-8320 Configuration and Installation*.



**Caution:** *Electrostatic discharge can damage several components on your PCI-MXI-2 module. To avoid such damage in handling the module, touch the antistatic plastic package to a metal part of your computer chassis before removing the PCI-MXI-2 from the package.*

## Configure the PCI-MXI-2

---

This section describes how to configure the following options on the PCI-MXI-2.

- Configuration EEPROM
- Onboard DRAM

Figure 2-1 shows the PCI-MXI-2. The drawing shows the location and factory-default settings on the module.

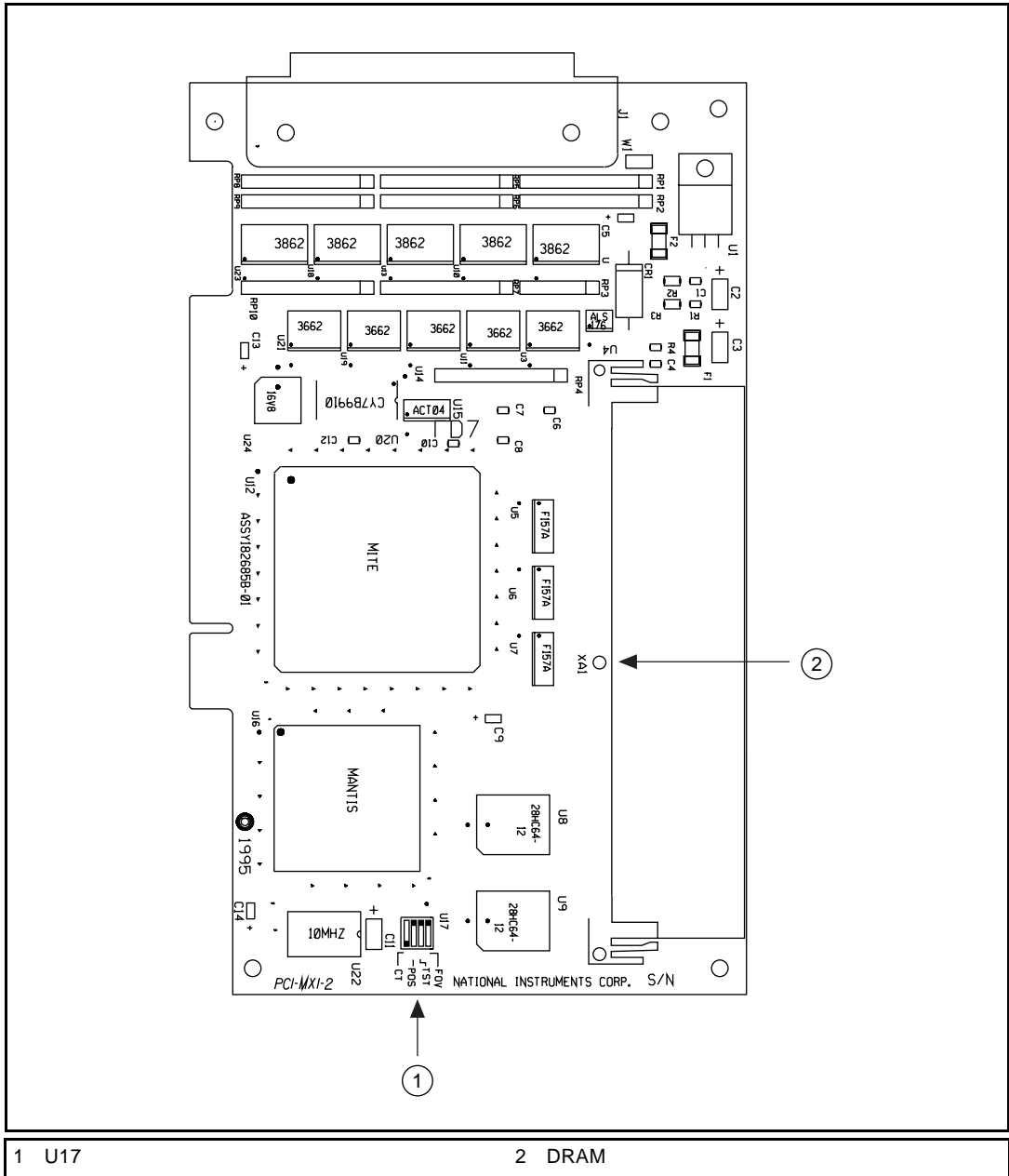

Figure 2-1. PCI-MXI-2 Parts Locator Diagram

## Configuration EEPROM

The PCI-MXI-2 has an onboard EEPROM, which stores default register values that are loaded at power-on. The EEPROM is divided into two halves—a factory-configuration half, and a user-configuration half—so you can modify the user-configurable half while the factory-configured half stores a back-up of the default user settings. The factory configuration is a minimal configuration that you can use to boot your PCI-MXI-2 regardless of the changes made to the user configuration.

For information about configuring the onboard EEPROM, refer to Appendix B, *EEPROM Configuration*.

## Onboard DRAM

The PCI-MXI-2 can accommodate one 72-pin DRAM SIMM. Table 2-1 lists the SIMM types you can use. You can use a 32-bit or 36-bit SIMM because DRAM parity is not required. The PCI-MXI-2 can hold up to 16 MB of onboard memory. The PCI-MXI-2 supports DRAM speeds of 80 ns or faster. The maximum allowable size for the DRAM SIMM is 1 in.

**Table 2-1.** PCI-MXI-2 DRAM Configurations

<b>SIMMs</b>	<b>Total DRAM</b>	<b>National Instruments Option?</b>
—	0	—
256 K x 32 or 256 K x 36	1 MB	—
1 M x 32 or 1 M x 36	4 MB	YES
4 M x 32 or 4 M x 36	16 MB	YES

## Install the PCI-MXI-2

---

This section contains general installation instructions for the PCI-MXI-2. Consult your computer user manual or technical reference manual for specific instructions and warnings.

1. Plug in your PCI-based computer before installing the PCI-MXI-2. The power cord grounds the computer and protects it from electrical damage while you install the module.



**Warning:** *To protect both yourself and the computer from electrical hazards, leave the computer off until you finish installing the PCI-MXI-2 module.*

2. Remove the top cover or access port to the PCI bus.
3. Select any available PCI expansion slot.
4. Locate the metal bracket that covers the cut-out in the back panel of the chassis for the slot you have selected. Remove and save the bracket-retaining screw and the bracket cover.
5. Touch the metal part of the power supply case inside the computer to discharge any static electricity that might be on your clothes or body.
6. Line up the PCI-MXI-2 with the MXI-2 connector near the cut-out on the back panel. Slowly push down on the top of the PCI-MXI-2 until its card-edge connector rests on the expansion slot receptacle. Using slow, evenly distributed pressure, press the PCI-MXI-2 straight down until it seats in the expansion slot.
7. Reinstall the bracket-retaining screw to secure the PCI-MXI-2 to the back panel rail.
8. Check the installation.
9. Replace the computer cover.

Figure 2-2 shows how to install the PCI-MXI-2.

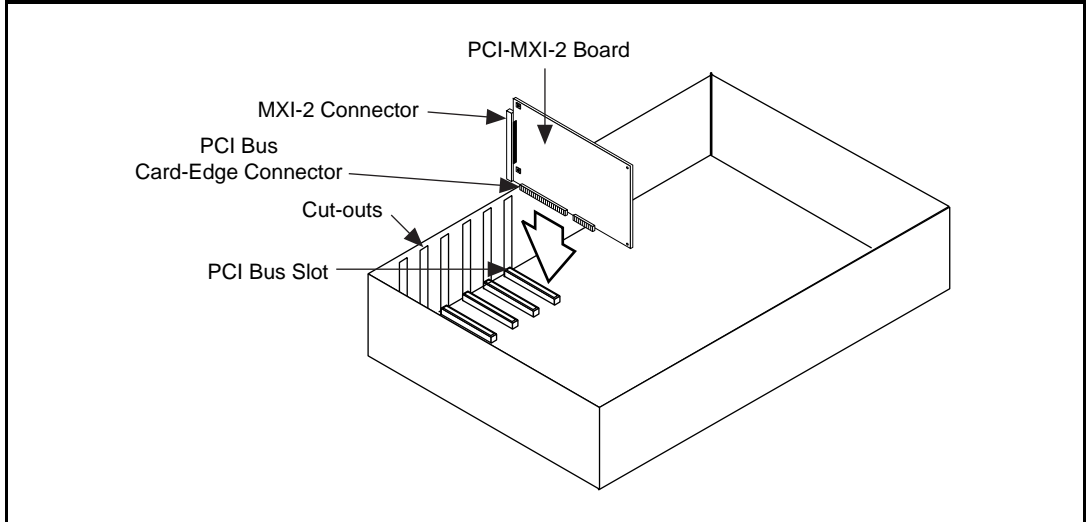

**Figure 2-2.** Installing the PCI-MXI-2 in a Computer

# PXI-8320 Configuration and Installation

---

Chapter

3

This chapter contains the instructions to configure and install the PXI-8320 module. This chapter applies only if your kit contains a PXI-8320. If you ordered a kit containing a PCI-MXI-2, refer to Chapter 2, *PCI-MXI-2 Configuration and Installation*.



**Caution:** *Electrostatic discharge can damage several components on your PXI-8320 module. To avoid such damage in handling the module, touch the antistatic plastic package to a metal part of your chassis before removing the PXI-8320 from the package.*

## Configure the PXI-8320

---

This section describes how to configure the following options on the PXI-8320.

- Configuration EEPROM
- Onboard DRAM

Figure 3-1 shows the PXI-8320. The drawing shows the location and factory-default settings on the module.

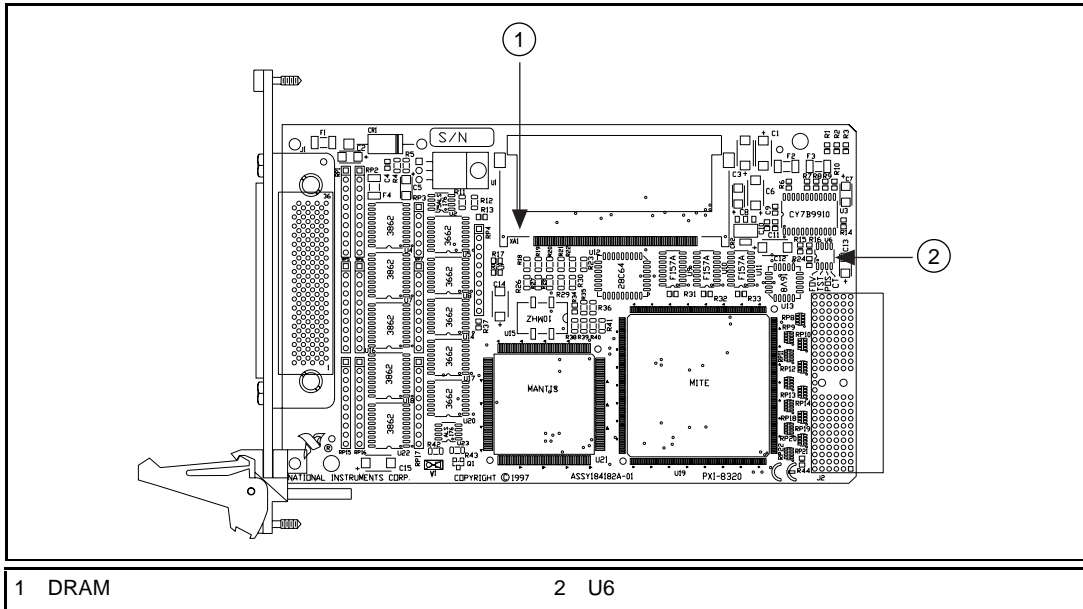

Figure 3-1. PXI-8320 Parts Locator Diagram

## Configuration EEPROM

The PXI-8320 has an onboard EEPROM, which stores default register values that are loaded at power-on. The EEPROM is divided into two halves—a factory-configuration half, and a user-configuration half—so you can modify the user-configurable half while the factory-configured half stores a back-up of the default user settings. The factory configuration is a minimal configuration that you can use to boot your PXI-8320 regardless of the changes made to the user configuration.

For information about configuring the onboard EEPROM, refer to Appendix B, *EEPROM Configuration*.

## Onboard DRAM

The PXI-8320 can accommodate one DRAM SO-DIMM. Table 3-1 lists the SO-DIMMs you can use. The PXI-8320 can hold up to 16 MB of onboard memory. The PXI-8320 supports DRAM speeds of 80 ns or faster.



**Table 3-1.** PXI-8320 DRAM Configurations

SO-DIMMs	Total DRAM	National Instruments Option?
—	0	—
1 M x 32	4 MB	YES
4 M x 32	16 MB	YES

## Install the PXI-8320

This section contains general installation instructions for the PXI-8320. Consult your chassis user manual or the *PXI-8320 User Manual* for specific instructions and warnings.

1. Plug in your PXI or CompactPCI chassis before installing the PXI-8320. The power cord grounds the chassis and protects it from electrical damage while you install the module.



**Warning:** *To protect both yourself and the chassis from electrical hazards, leave the chassis off until you finish installing the PXI-8320 module.*

2. Select any available PXI or CompactPCI peripheral slot. Do *not* use the first slot, which is designated for the system controller, such as the National Instruments PXI-8150 Series embedded computer. See Figure 3-2.
3. Locate the metal bracket that covers the slot of the chassis for the slot you have selected. Remove and save the cover.
4. Touch the metal part of the case to discharge any static electricity that might be on your clothes or body.
5. Make sure the injector/ejector handle is in its downward position. Line up the PXI-8320 with the card guides on the slot of the PXI/CompactPCI peripheral slot.



**Caution:** *Do not raise the injector/ejector handle as you insert the PXI-8320. The module will not insert properly unless the handle is in its downward position so that it does not interfere with the injector rail on the chassis.*

6. Slide the board into the mainframe until the handle catches on the injector/ejector rail.

7. Raise the injector/ejector handle until the module firmly seats into the backplane.
8. Screw in the bracket-retaining screw at the top of the module to secure the PXI-8320 to the chassis.
9. Check the installation.

Figure 3-2 shows how to install the PXI-8320. The National Instruments PXI-8156 is shown installed in the system controller slot of the PXI chassis. Place the PXI-8320 and any other PXI boards in any other slot.

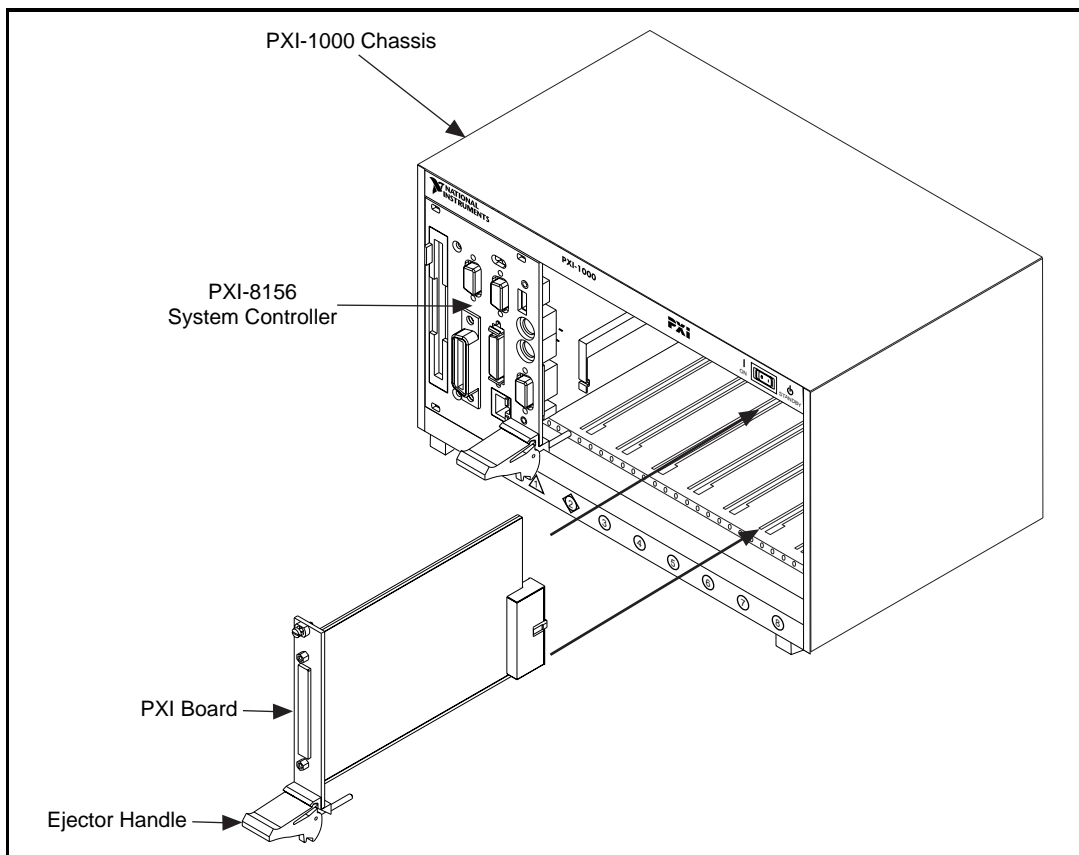

**Figure 3-2.** Installing the PXI-8320 in a PXI Chassis

# VXI-MXI-2 Configuration and Installation

---

Chapter

4

This chapter contains the instructions to configure and install the VXI-MXI-2 module. This chapter applies only if your kit contains a C-size VXI-MXI-2. If you have a B-size VXI-MXI-2, refer to Chapter 5, *VXI-MXI-2/B Configuration and Installation*. If you ordered the VME kit, skip this chapter and refer to Chapter 6, *VME-MXI-2 Configuration and Installation*.

Configuring the VXI-MXI-2 is optional. A typical configuration can use the default settings.



**Caution:** *Electrostatic discharge can damage several components on your VXI-MXI-2 module. To avoid such damage in handling the module, touch the antistatic plastic package to a metal part of your VXI chassis before removing the VXI-MXI-2 from the package.*

## Configure the VXI-MXI-2

---

This section describes how to configure the following options on the VXI-MXI-2.

- VXIbus logical address
- VXIbus Slot 0/Non-Slot 0
- VXIbus CLK10 routing
- Trigger input termination
- MXIbus termination
- Configuration EEPROM
- Onboard DRAM
- VXIbus local bus

Figure 4-1 shows the right-side cover of the VXI-MXI-2. The drawing shows the location and factory-default settings of the configuration switches and jumpers on the module. Notice that you can access switch S6 (called out as number 8 in the drawing) only by removing the front cover.

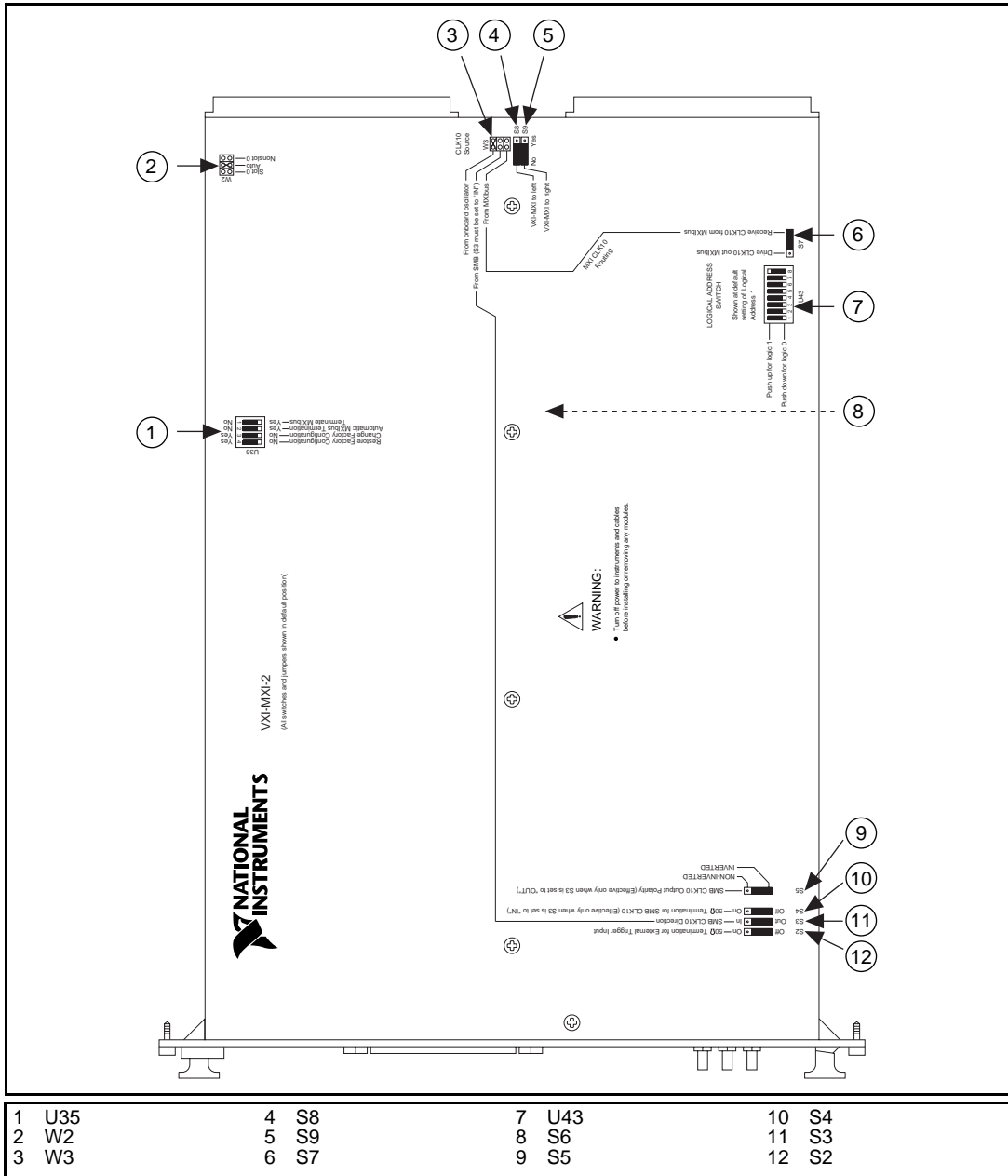

Figure 4-1. VXI-MXI-2 Right-Side Cover

## Front Panel Features

The VXI-MXI-2 has the following front panel features.

- Three front panel LEDs
  - **SYSFAIL** LED indicates that the VMEbus SYSFAIL line is asserted.
  - **MXI** LED indicates when the VXI-MXI-2 is accessed from the MXIbus.
  - **VXI** LED indicates when the VXI-MXI-2 is accessed from the VXIbus.
- MXIbus connector
- Three SMB connectors
  - External clock
  - Trigger output
  - Trigger input
- System reset push-button

## Removing the Metal Enclosure

The VXI-MXI-2 is housed in a metal enclosure to improve EMC performance and to provide easy handling. Because the enclosure includes cutouts to facilitate changes to the switch and jumper settings, you do not need to remove it under normal circumstances.

However, you must remove the enclosure if you want to change the amount of DRAM installed on the VXI-MXI-2. Switch S6, which is directly related to the amount of DRAM you want to install, is also accessible only by removing the enclosure. If you wish to change the amount of onboard DRAM, remove the four screws on the top, the four screws on the bottom, and the five screws on the right-side cover of the enclosure. Refer to the *Onboard DRAM* section later in this chapter for details about changing DRAM.

## VXIbus Logical Address

Each device in a VXIbus/MXIbus system is assigned a unique number between 0 and 254. This 8-bit number, called the *logical address*, defines the base address for the VXI configuration registers located on the device. With unique logical addresses, each VXIbus device in the system is assigned 64 bytes of configuration space in the upper 16 KB of A16 space.

Logical address 0 is reserved for the Resource Manager in the VXIbus system. Because the VXI-MXI-2 cannot act as a Resource Manager, do not configure the VXI-MXI-2 with a logical address of 0.

Some VXIbus devices have *dynamically configurable* logical addresses. These devices have an initial logical address of hex FF or 255, which indicates that they can be dynamically configured. While the VXI-MXI-2 does support dynamic configuration of VXI devices within its mainframe, it is itself a *statically configured* device and is preset at the factory with a VXI logical address of 1.

Ensure that no other statically configurable VXIbus devices have a logical address of 1. If they do, change the logical address setting of either the VXI-MXI-2 or the other device so that every device in the system has a unique associated logical address.

You can change the logical address of the VXI-MXI-2 by changing the setting of the 8-bit DIP switch labeled *LOGICAL ADDRESS SWITCH* (location designator U43) on the panel. The down position of the DIP switch corresponds to a logic value of 0 and the up position corresponds to a logic value of 1. Verify that the VXI-MXI-2 does not have the same logical address as any other statically configured VXIbus device in your system. Remember that logical addresses hex 0 and FF are not allowed for the VXI-MXI-2. Also, when setting logical addresses, keep in mind the grouping requirements set by the system hierarchy. See VXI-6, *VXIbus Mainframe Extender Specification*, for more information on setting logical addresses on a multimainframe hierarchy.

Figure 4-2 shows switch settings for logical addresses hex 1 and C0.

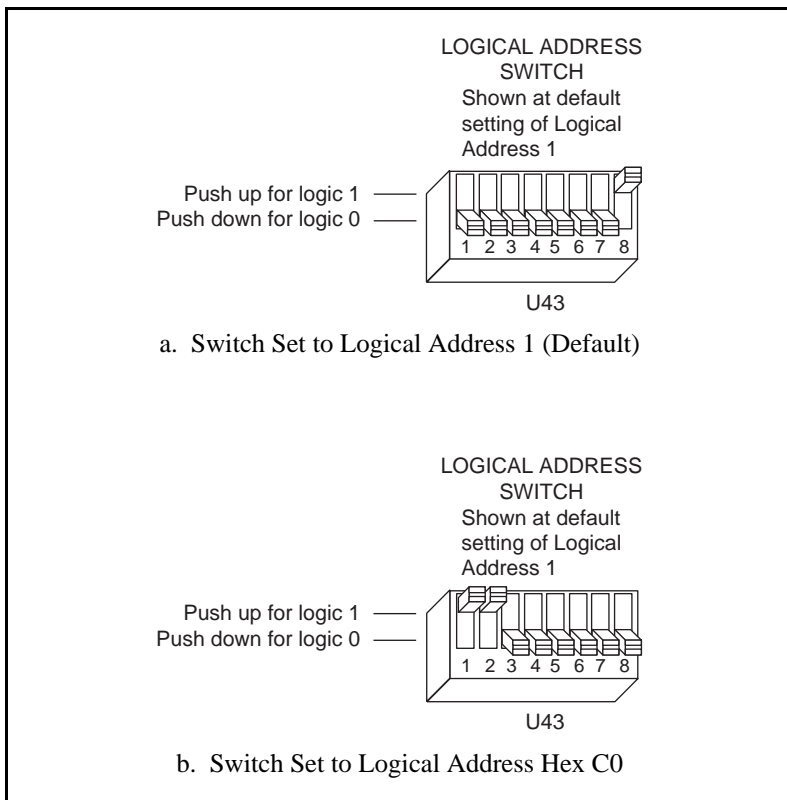

**Figure 4-2.** Logical Address Selection

## VXIbus Slot 0/Non-Slot 0

The VXI-MXI-2 is configured at the factory to automatically detect if it is installed in Slot 0 of a VXIbus mainframe. With automatic Slot 0 detection, you can install the VXI-MXI-2 into any VXIbus slot.

You can manually configure the VXI-MXI-2 for either Slot 0 or Non-Slot 0 operation by defeating the automatic-detection circuitry. Use the three-position jumper W2 to select automatic Slot 0 detection, Slot 0, or Non-Slot 0 operation. Figure 4-3 shows these three settings.



**Warning:** *Do not install a device configured for Slot 0 into another slot without first reconfiguring it to either Non-Slot 0 or automatic configuration. Neglecting to do this could damage the device, the VXIbus backplane, or both.*

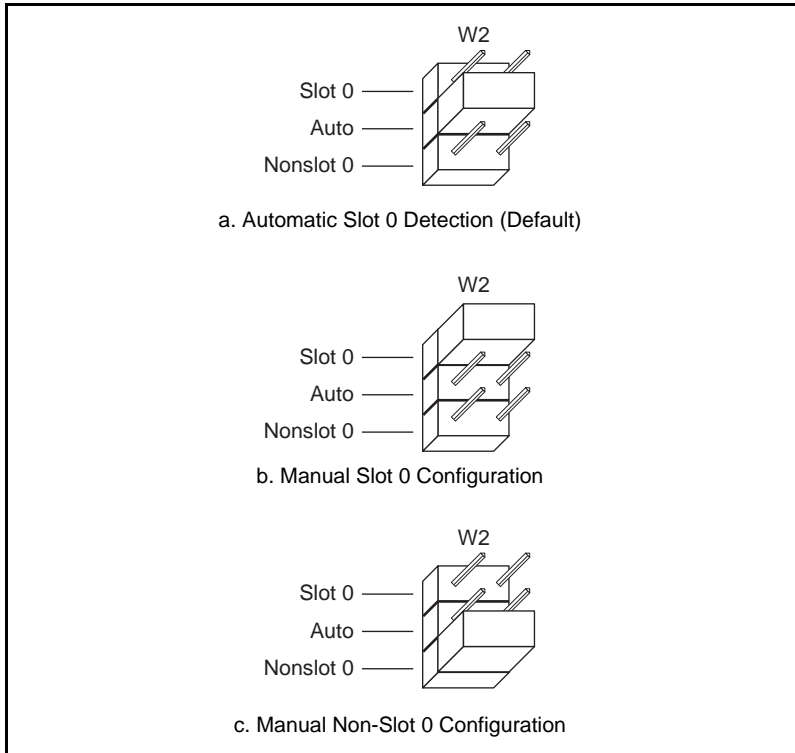

**Figure 4-3.** VXIbus Slot Configuration

When the VXI-MXI-2 is installed in Slot 0, it becomes the VMEbus System Controller. In this role, it has VMEbus Data Transfer Bus Arbiter circuitry that accepts bus requests on all four VMEbus request levels, prioritizes the requests, and grants the bus to the highest-priority requester. As VMEbus System Controller, the VXI-MXI-2 also drives the 16 MHz VMEbus system clock using an onboard 16 MHz oscillator.

As required by the VXIbus specification, the VXI-MXI-2 drives the 10 MHz signal CLK10 on a differential ECL output when installed in Slot 0. When not installed in Slot 0, the VXI-MXI-2 only receives the CLK10 signal.

## VXIbus CLK10 Routing

When you install it in Slot 0 of your mainframe, the VXI-MXI-2 supplies the VXIbus CLK10 signal. The VXI-MXI-2 can use three different sources to generate this signal: an onboard oscillator, the



external CLK SMB connector, and the MXIbus CLK10 signal. Use the three-position jumper W3 to select these options, as shown in Figure 4-4.

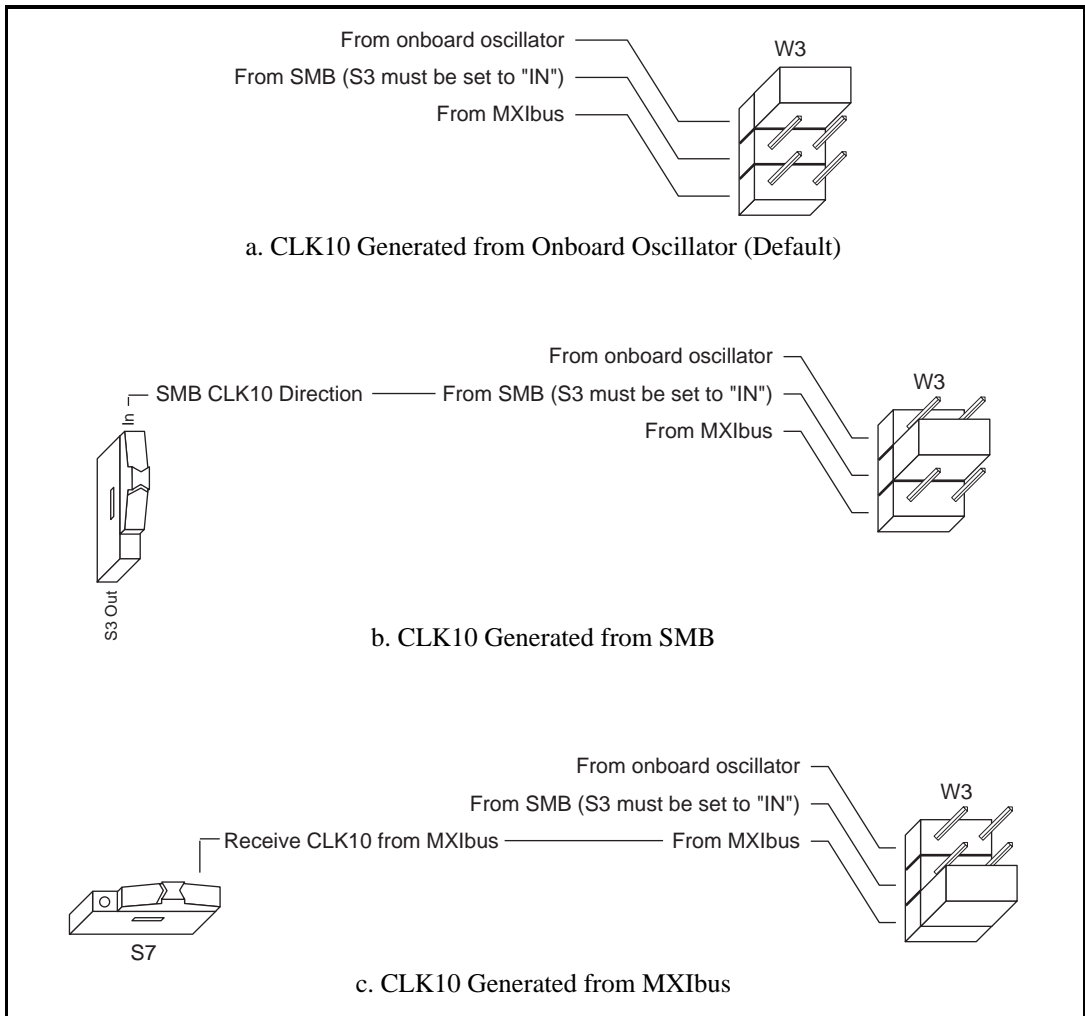

**Figure 4-4.** VXIbus CLK10 Routing

Notice that Figure 4-4b and Figure 4-4c also show switches S3 and S7, respectively. You must configure these switches as shown when using the corresponding CLK10 source setting of W3.

You can also configure the VXI-MXI-2 to drive the external CLK SMB signal from the VXIBus CLK10 signal. Switch S3 controls whether the VXI-MXI-2 drives or receives the external CLK SMB signal. If you change the S3 setting to drive CLK10 out the external CLK10 SMB connector, do not set the W3 jumper to receive the SMB CLK10 signal; instead use the settings shown in either Figure 4-4a or Figure 4-4c as appropriate.

When switch S3 is set so that the VXI-MXI-2 receives the SMB CLK10 signal, you have the option to add a 50  $\Omega$  termination to the signal by setting switch S4. S4 is unused—its setting does not matter—when S3 is configured to drive the external CLK SMB signal.

You can use an additional switch, S5, to control the polarity of the external CLK SMB signal when S3 is configured to drive it. S5 is unused—its setting does not matter—when S3 is configured to receive the external CLK SMB signal.

Figure 4-5 shows four configuration settings for the VXI-MXI-2. Figure 4-5a shows the default configuration, which is for driving the inverted external CLK SMB. Use the settings of Figure 4-5b to drive the non-inverted external CLK SMB signal. Figure 4-5c illustrates the setting for receiving the external CLK SMB signal. Finally, you can configure the switches as shown in Figure 4-5d to receive the external CLK SMB signal with a 50  $\Omega$  termination.



**Note:** *The settings of any switches shown with this pattern (  ) have no bearing on the configuration described in any of the following figures.*

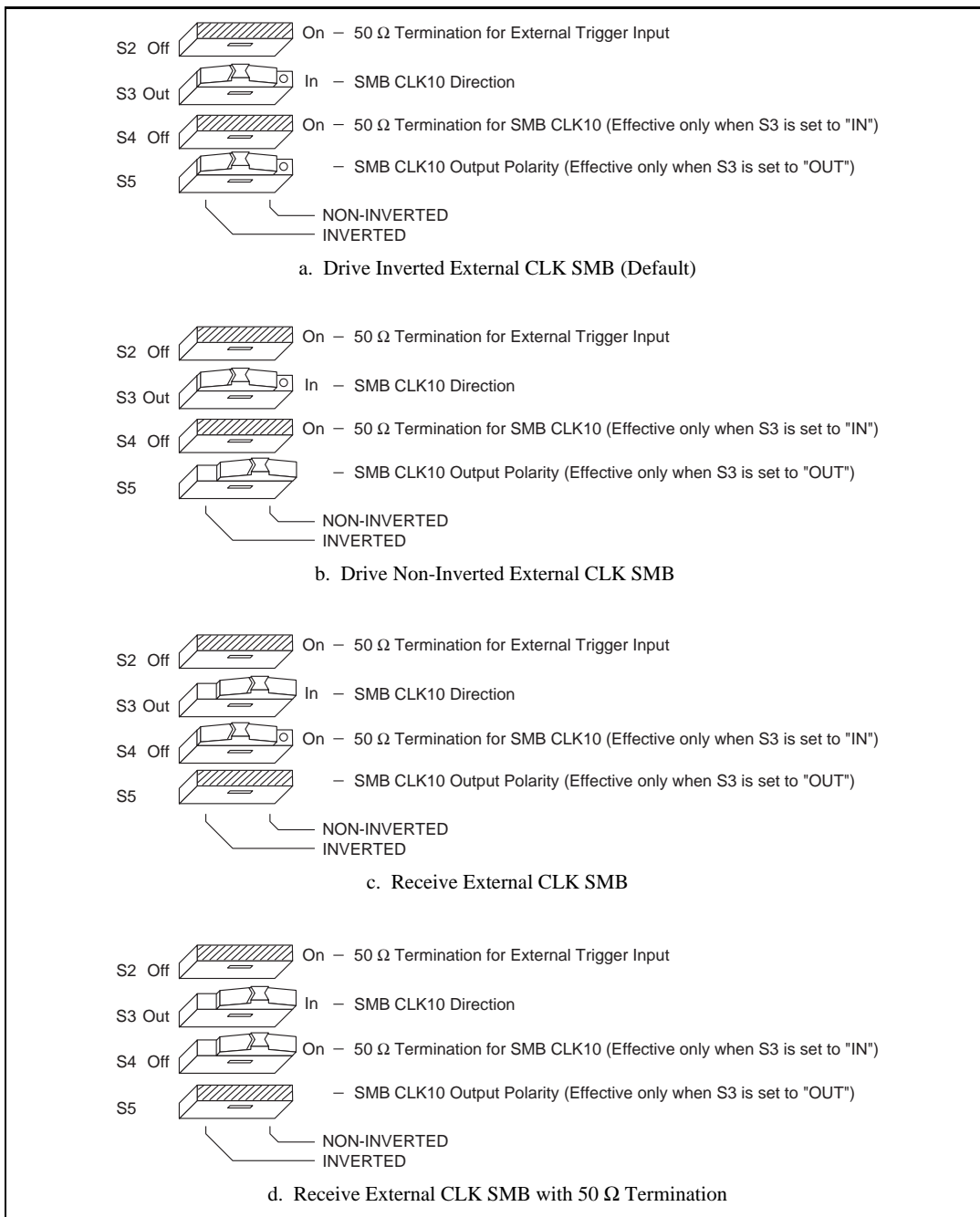

**Figure 4-5.** SMB CLK10 Settings

The VXI-MXI-2 can also drive or receive the MXIbus CLK10 signal. Switch S7 controls whether the VXI-MXI-2 drives MXIbus CLK10 from the VXIbus CLK10 or receives MXIbus CLK10. As shown in Figure 4-4c, if W3 is configured to use the MXIbus CLK10 to generate the VXIbus CLK10 signal, switch S7 must be configured to receive MXIbus CLK10. This is shown again in Figure 4-6a. If you change the S7 setting to drive CLK10 out the MXIbus, do not set the W3 jumper to receive the MXIbus CLK10; instead use the settings shown in Figure 4-4a or Figure 4-4b as appropriate.



**Caution:** *Do not configure more than one MXIbus device to drive the MXIbus CLK10. Having a second device driving MXIbus CLK10 could damage the device.*

Figure 4-6 shows the configuration settings for receiving and driving MXIbus CLK10, respectively.

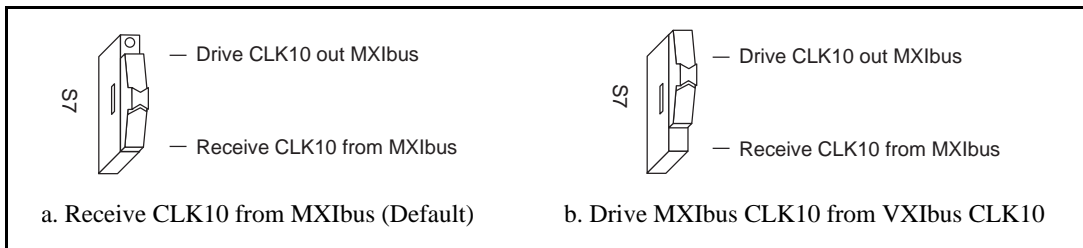

**Figure 4-6.** Receiving or Driving MXIbus CLK10

## Trigger Input Termination

You can use switch S2 to terminate the external trigger input SMB with 50  $\Omega$ . Figure 4-7a shows the default setting for a non-terminated trigger input SMB. Use the setting of Figure 4-7b to terminate the trigger input SMB. Switch S2 is located above switches S3, S4, and S5, which have no effect on this configuration.

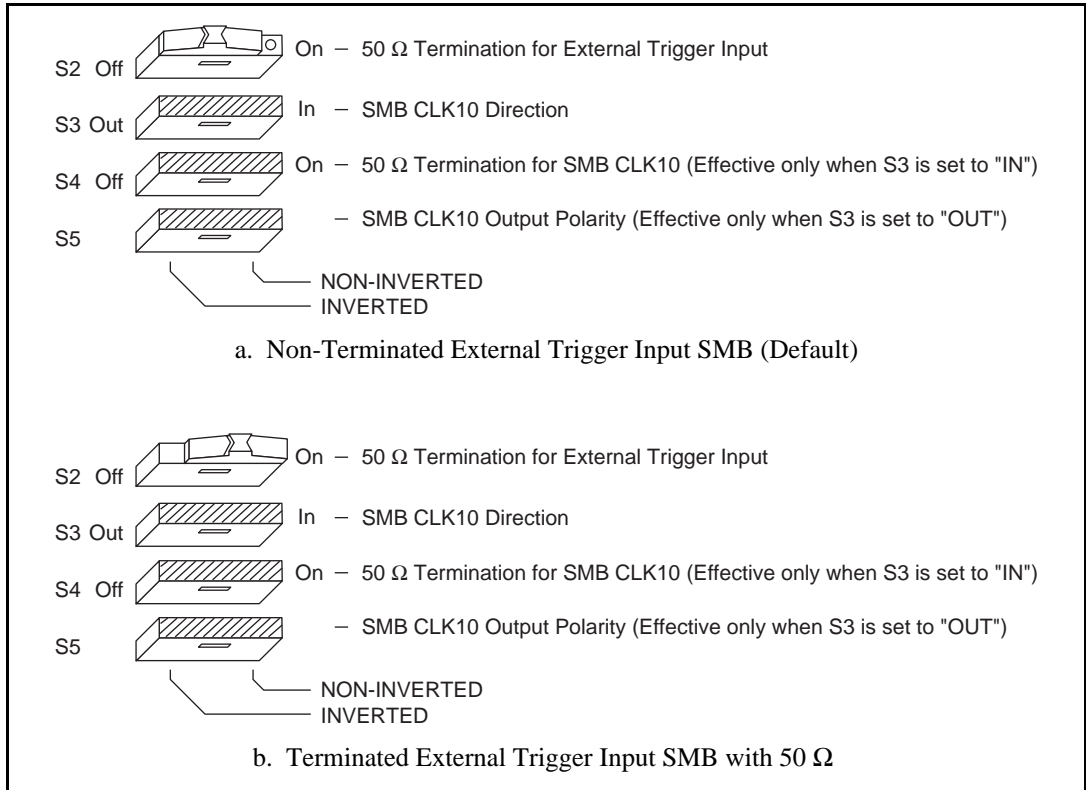

Figure 4-7. SMB Trigger Input Termination

## MXIbus Termination

The first and last MXIbus devices connected to the MXIbus—whether using a single MXI-2 cable or daisy-chained MXI-2 cables—must terminate the MXIbus. Any MXIbus devices in the middle of a MXIbus daisy chain must *not* terminate the MXIbus.

The VXI-MXI-2 automatically senses whether it is at either end of the MXIbus cable to terminate the MXIbus. You can manually control MXIbus termination by defeating the automatic circuitry. Use switches 1 and 2 of the four-position switch at location U35 to control whether MXIbus termination is automatic (Figure 4-8a), on (Figure 4-8b), or off (Figure 4-8c). The settings of switches 3 and 4 have no effect on MXIbus termination.

Use switch 2 of U35 to select whether the VXI-MXI-2 automatically controls termination of the MXIbus. Notice in Figure 4-8a that switch 1 has no effect when switch 2 is set for automatic MXIbus termination.

If you want to control termination manually, you must turn off switch 2. You can then use switch 1 of U35 to manually control whether to terminate the MXIbus.

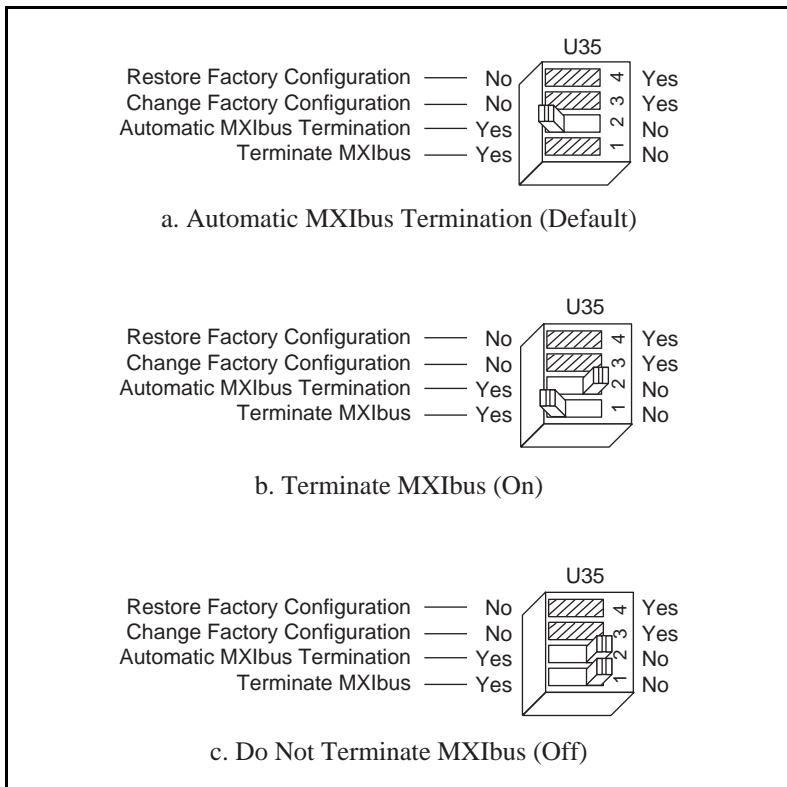

Figure 4-8. MXIbus Termination

## Configuration EEPROM

The VXI-MXI-2 has an onboard EEPROM, which stores default register values that are loaded at power-on. The EEPROM is divided into two halves—a factory-configuration half and a user-configuration half—so you can modify the user-configurable half while the factory-configured half stores a back-up of the default user settings.

Use switches 3 and 4 of the four-position switch at location U35 to control the operation of the EEPROM. The Restore Factory Configuration switch (switch 4) causes the VXI-MXI-2 to boot from the factory-configured half instead of the user-modified settings. This is useful in the event that the user-configured half of the EEPROM becomes corrupted in such a way that the VXI-MXI-2 boots to an unusable state.

The Change Factory Configuration switch (switch 3 of U35) lets you change the factory-default configuration settings by permitting writes to the factory settings section of the EEPROM. This switch serves as a safety measure and is not needed under normal circumstances. When this switch is off (its default setting), the factory configuration of the EEPROM is protected, so any writes to the factory area are ignored. The factory area is protected regardless of the setting of switch 4 of U35.

Figure 4-9 shows the configuration settings for EEPROM operation. The settings of switches 1 and 2 have no effect on EEPROM configuration.

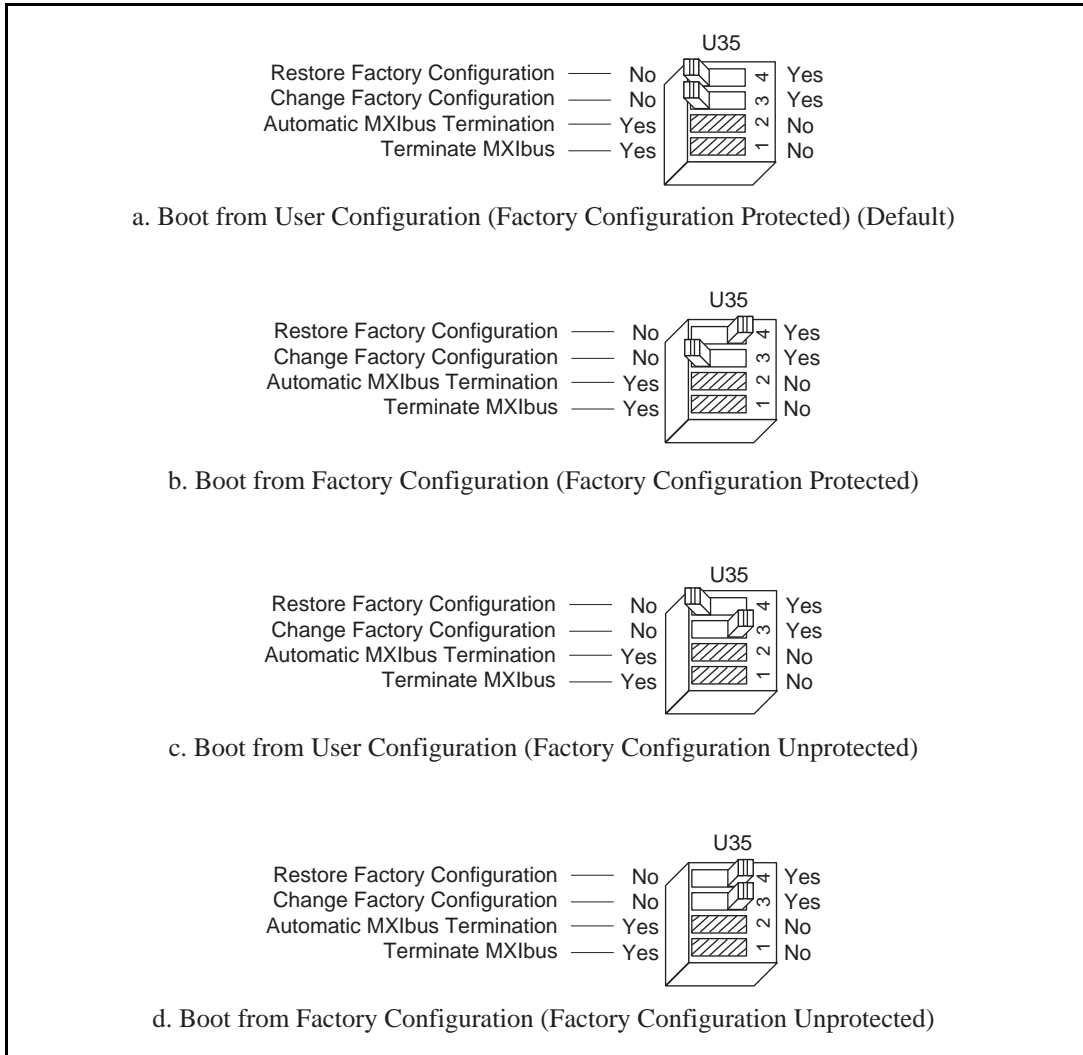

Figure 4-9. EEPROM Operation

## Onboard DRAM

The VXI-MXI-2 can accommodate up to two 1.35 in. 72-pin DRAM SIMMs. You must remove the metal enclosure to access the SIMM sockets and a switch that selects the SIMM size. To access these components, remove the four screws on the top, the four screws on the bottom, and the five screws on the right-side cover of the metal enclosure.



Table 4-1 lists the SIMM types you can use. You can use 32-bit or 36-bit SIMMs, because DRAM parity is not required. Because the VXI-MXI-2 supports only one organization at a time, all SIMMs installed must be of the same type. Use Bank 0 first when installing the SIMMs, and use Bank 1 when you need to install a second, matching SIMM. As shown in Table 4-1, you can install up to 64 MB. The VXI-MXI-2 supports DRAM speeds of 80 ns or faster.

Use switch S6 to select the size of each SIMM. If the SIMMs are 4 M × 32 or larger, set S6 to the OFF setting as shown in Figure 4-10a. For SIMMs *smaller* than 4 M × 32, use the ON setting as shown in Figure 4-10b.

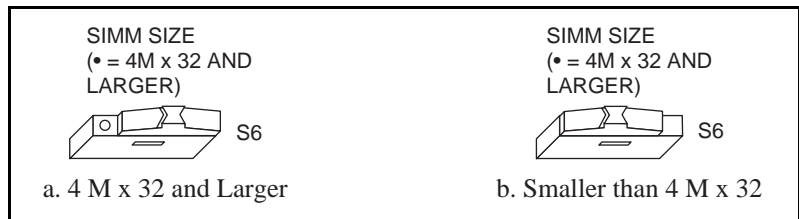

**Figure 4-10.** SIMM Size Configuration

Refer to Table 4-1 for how to adjust the switch (ON or OFF) for all supported DRAM configurations. Many of the DRAM options are available from National Instruments.



**Note:** *After installing DRAM on the VXI-MXI-2, you need to enable the memory through the T&M Explorer utility.*

**Table 4-1.** VXI-MXI-2 DRAM Configurations

Bank 0	Bank 1	Total DRAM	National Instruments Option?	Switch Setting of S6
—	—	0	—	—
256 K × 32 or 256 K × 36	—	1 MB	—	ON
256 K × 32 or 256 K × 36	256 K × 32 or 256 K × 36	2 MB	—	ON
512 K × 32 or 512 K × 36	—	2 MB	—	ON

**Table 4-1.** VXI-MXI-2 DRAM Configurations (Continued)

Bank 0	Bank 1	Total DRAM	National Instruments Option?	Switch Setting of S6
512 K × 32 or 512 K × 36	512 K × 32 or 512 K × 36	4 MB	—	ON
1 M × 32 or 1 M × 36	—	4 MB	YES	ON
1 M × 32 or 1 M × 36	1 M × 32 or 1 M × 36	8 MB	—	ON
2 M × 32 or 2 M × 36	—	8 MB	YES	ON
2 M × 32 or 2 M × 36	2 M × 32 or 2 M × 36	16 MB	—	ON
4 M × 32 or 4 M × 36	—	16 MB	YES	OFF
4 M × 32 or 4 M × 36	4 M × 32 or 4 M × 36	32 MB	—	OFF
8 M × 32 or 8 M × 36	—	32 MB	YES	OFF
8 M × 32 or 8 M × 36	8 M × 32 or 8 M × 36	64 MB	YES	OFF



**Caution:** *If you install DRAM into the VXI-MXI-2, do not attempt to use the first 4 KB of memory space. This 4 KB space maps to the registers on the VXI-MXI-2 and does not access onboard DRAM. Accessing this region will cause your VXI-MXI-2 to behave incorrectly.*

## VXIbus Local Bus

If you are installing more than one VXI-MXI-2 in a single VXIbus mainframe, you must configure the boards to use the local bus. The VXI-MXI-2 uses the local bus to pass a signal to the other VXI-MXI-2 modules in the mainframe to disable the VMEbus bus timeout unit (BTO) during cycles that map to the MXIbus. Because the local bus is used, you must install all VXI-MXI-2 modules for a single mainframe in adjacent slots.

Switches S8 and S9 on the VXI-MXI-2 select its position in relation to any other VXI-MXI-2 module in the mainframe. Use switch S9 when there is a VXI-MXI-2 to the right (higher-numbered slot). Use S8 when there is a VXI-MXI-2 to the left (lower-numbered slot).

Figure 4-11 shows four configuration settings for a VXI-MXI-2. Figure 4-11a illustrates the default setting, which is for a single VXI-MXI-2 in a mainframe. Use the setting in Figure 4-11b for the VXI-MXI-2 located to the left of all others. Figure 4-11c shows the setting to use if the VXI-MXI-2 is between two others. Use the setting of Figure 4-11d for the VXI-MXI-2 located to the right of all others.

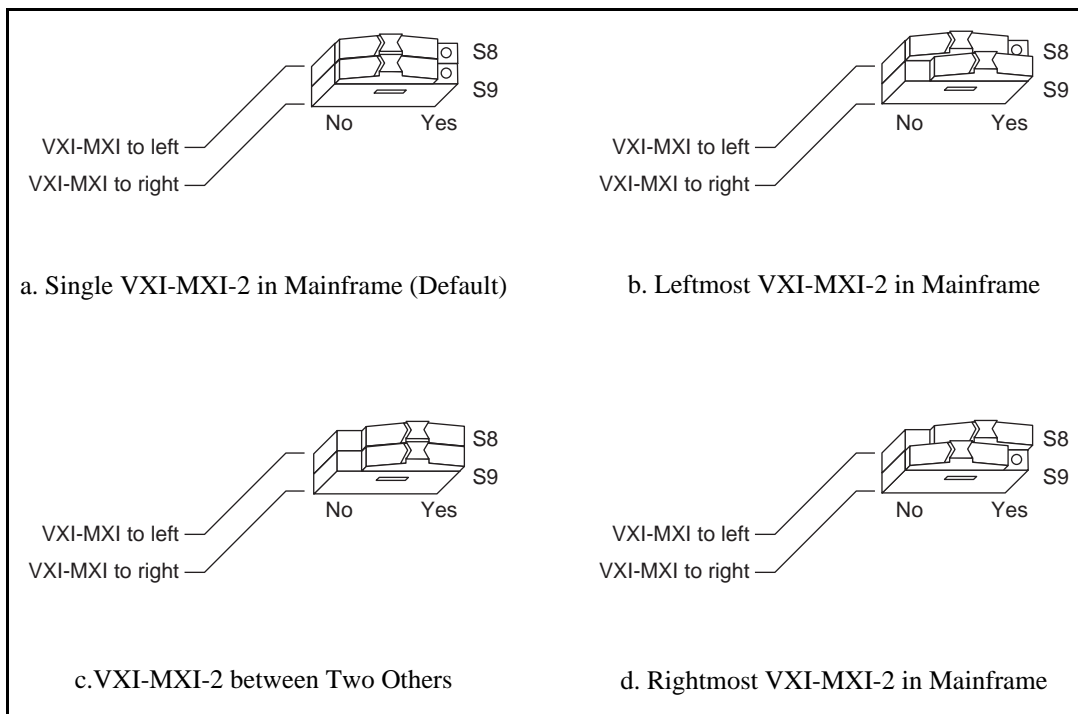

**Figure 4-11.** VXIbus Local Bus Configuration

## Install the VXI-MXI-2

---

This section contains general installation instructions for the VXI-MXI-2. Consult your VXIbus mainframe user manual or technical reference manual for specific instructions and warnings.

1. Plug in your mainframe before installing the VXI-MXI-2. The power cord grounds the mainframe and protects it from electrical damage while you install the module.



**Warning:** *To protect both yourself and the mainframe from electrical hazards, leave the mainframe off until you finish installing the VXI-MXI-2 module.*

2. Remove or open any doors or covers blocking access to the mainframe slots.
3. If you are installing the VXI-MXI-2 into a D-size mainframe, install a support designed for installing C-size boards in D-size mainframes. The VXI-MXI-2 has no P3 connector and cannot provide P3 Slot 0 control to VXI devices requiring this capability.



**Caution:** *If the VXI-MXI-2 is not configured for automatic Slot 0 detection, be certain that the slot you select in your VXIbus mainframe matches the VXI-MXI-2 configuration as either a Slot 0 device or a Non-Slot 0 device. If you install your VXI-MXI-2 into a slot that does not correspond with the jumper setting, you risk damage to the VXI-MXI-2, the VXIbus backplane, or both.*

4. Insert the VXI-MXI-2 in the slot you have selected by aligning the top and bottom of the board with the card-edge guides inside the mainframe. Slowly push the VXI-MXI-2 straight into the slot until its plug connectors rest on the backplane receptacle connectors. Using slow, evenly distributed pressure, press the VXI-MXI-2 straight in until it seats in the expansion slot. The front panel of the VXI-MXI-2 should be even with the front panel of the mainframe.
5. Tighten the retaining screws on the top and bottom edges of the front panel.
6. Check the installation.
7. Connect the cables as described in the following section before restoring power.
8. Replace or close any doors or covers to the mainframe.

## Connect the MXIbus Cable

---

There are two basic types of MXI-2 cables. MXI-2 cables can have either a single connector on each end or a single connector on one end and a double connector on the other end.

Connect the labeled end of the cable to the MXI-2 device that will be the MXIbus System Controller. Connect the other end of the cable to the other device. Be sure to tighten the screw locks to ensure proper pin connection.

Figure 4-12 shows the correct cabling for a VXI system containing a PCI-MXI-2 board in a PCI-based computer cabled to a VXI-MXI-2 module residing in Slot 0 of a VXIbus mainframe. The cabling scheme is the same for a PXI-8320 board installed in a PXI/CompactPCI chassis. Notice that you can expand your system to include other devices by using an additional MXI-2 cable. However, in such a case the first cable must have a double connector on one end. You can use a cable with a single connector on each end to connect the last device on the MXIbus.

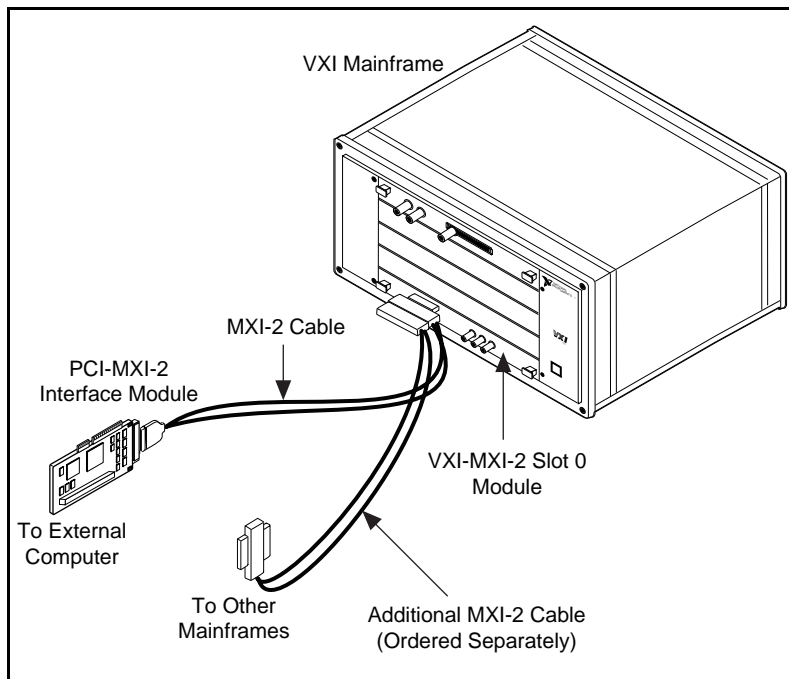

**Figure 4-12.** MXI-2 Cable Configuration Using a PCI-MXI-2 and a VXI-MXI-2

When you have properly connected the MXI-2 cable, power on the VXIbus mainframe and then the computer.



**Note:** *Always turn on the mainframe first. Doing so makes it possible for your external computer to access the VXI boards in the mainframe upon startup.*

# VXI-MXI-2/B Configuration and Installation

---

Chapter

5

This chapter contains the instructions to configure and install the VXI-MXI-2/B module. This chapter applies only if your kit contains a B-size VXI-MXI-2. If you have a C-size VXI-MXI-2, see Chapter 4, *VXI-MXI-2 Configuration and Installation*. If you have a VME-MXI-2, refer to Chapter 6, *VME-MXI-2 Configuration and Installation*.

Configuring the VXI-MXI-2/B is optional. A typical configuration can use the default settings.



**Caution:** *Electrostatic discharge can damage several components on your VXI-MXI-2/B module. To avoid such damage in handling the module, touch the antistatic plastic package to a metal part of your VXI chassis before removing the VXI-MXI-2/B from the package.*

## Configure the VXI-MXI-2/B

---

This section describes how to configure the following options on the VXI-MXI-2/B.

- VXIbus logical address
- VXIbus Slot 0/Non-Slot 0
- VXIbus CLK10 routing
- Trigger input termination
- MXIbus termination
- Configuration EEPROM
- Onboard DRAM
- VXIbus local bus

Figure 5-1 shows the location and factory-default settings of the configuration switches and jumpers on the VXI-MXI-2/B.

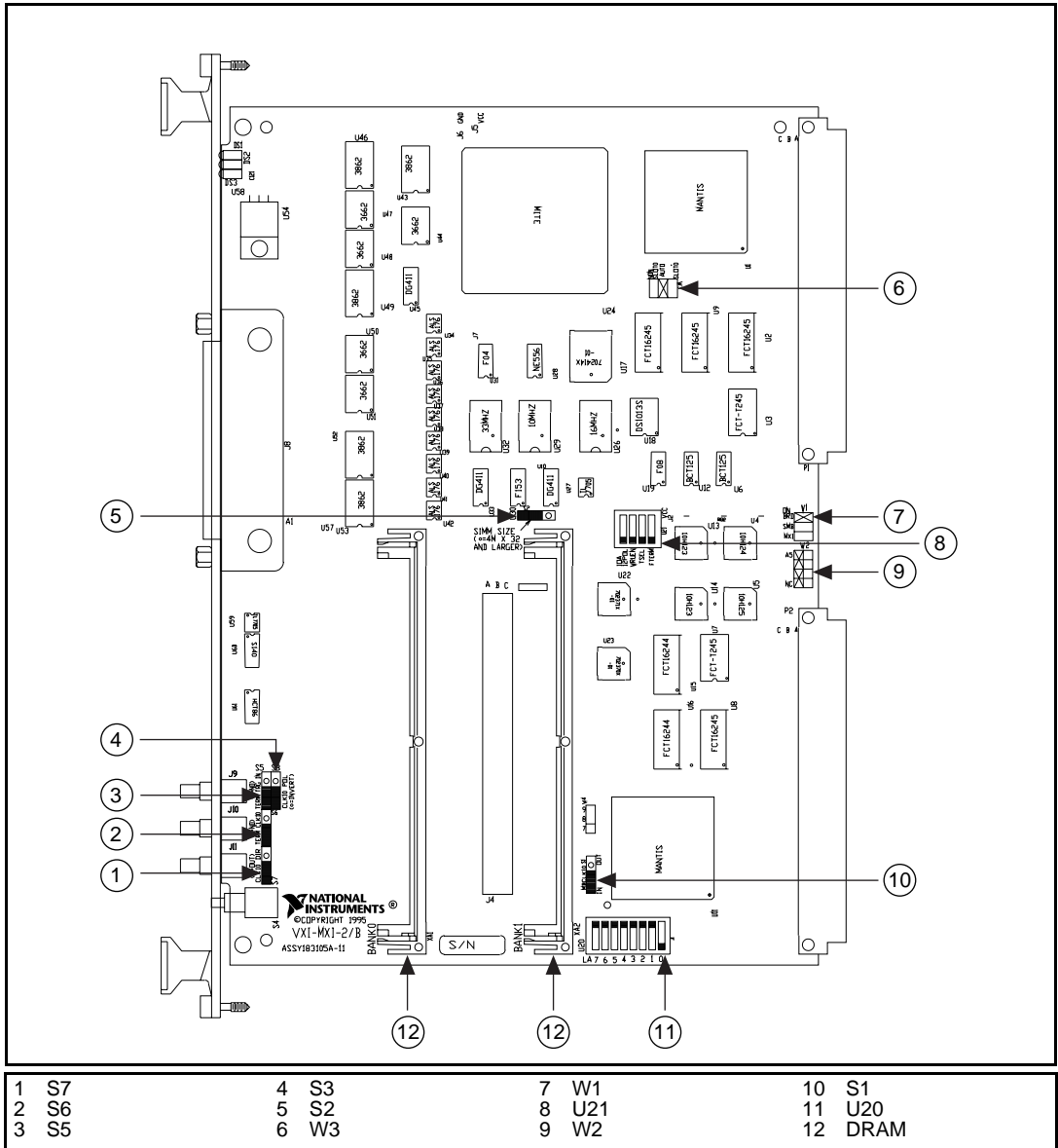

Figure 5-1. VXI-MXI-2/B Parts Locator Diagram



## Front Panel Features

The VXI-MXI-2/B has the following front panel features.

- Three front panel LEDs
  - **SYSFAIL** LED indicates that the VMEbus SYSFAIL line is asserted.
  - **MXI** LED indicates when the VXI-MXI-2/B is accessed from the MXIbus.
  - **VXI** LED indicates when the VXI-MXI-2/B is accessed from the VXIbus.
- MXIbus connector
- Three SMB connectors
  - Trigger input
  - Trigger output
  - External clock
- System reset push-button

## VXIbus Logical Address

Each device in a VXIbus/MXIbus system is assigned a unique number between 0 and 254. This 8-bit number, called the *logical address*, defines the base address for the VXI configuration registers located on the device. With unique logical addresses, each VXIbus device in the system is assigned 64 bytes of configuration space in the upper 16 KB of A16 space.

Logical address 0 is reserved for the Resource Manager in the VXIbus system. Because the VXI-MXI-2/B cannot act as a Resource Manager, do not configure the VXI-MXI-2/B with a logical address of 0.

Some VXIbus devices have *dynamically configurable* logical addresses. These devices have an initial logical address of hex FF or 255, which indicates that they can be dynamically configured. While the VXI-MXI-2/B does support dynamic configuration of VXI devices within its mainframe, it is itself a *statically configured* device and is preset at the factory with a VXI logical address of 1.

Ensure that no other statically configurable VXIbus devices have a logical address of 1. If they do, change the logical address setting of either the VXI-MXI-2/B or the other device so that every device in the system has a unique associated logical address.

You can change the logical address of the VXI-MXI-2/B by changing the setting of the 8-bit DIP switch at location designator U20 (See Figure 5-1). The ON position of the DIP switch corresponds to a logic value of 0 and the OFF position corresponds to a logic value of 1. Verify that the VXI-MXI-2/B does not have the same logical address as any other statically configured VXIbus device in your system. Remember that logical addresses hex 0 and FF are not allowed for the VXI-MXI-2/B. Also, when setting logical addresses, keep in mind the grouping requirements set by the system hierarchy. See VXI-6, *VXIbus Mainframe Extender Specification*, for more information on setting logical addresses on a multimainframe hierarchy.

Figure 5-2 shows switch settings for logical addresses hex 1 and C0.

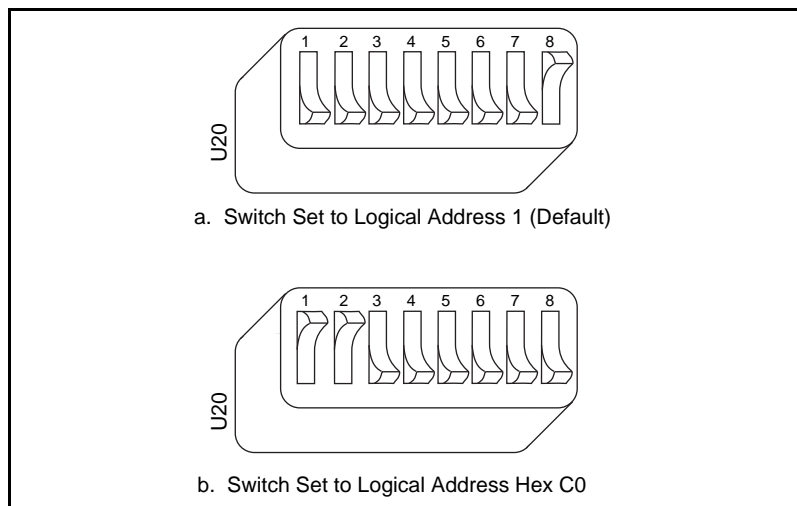

**Figure 5-2.** Logical Address Selection

## VXIbus Slot 0/Non-Slot 0

The VXI-MXI-2/B is configured at the factory to automatically detect if it is installed in Slot 0 of a VXIbus mainframe. With automatic Slot 0 detection, you can install the VXI-MXI-2/B into any VXIbus slot.

You can manually configure the VXI-MXI-2/B for either Slot 0 or Non-Slot 0 operation by defeating the automatic-detection circuitry. Use the three-position jumper W3 to select automatic Slot 0 detection, Slot 0, or Non-Slot 0 operation. Figure 5-3 shows these three settings.



**Caution:** *Do not install a device configured for Slot 0 into another slot without first reconfiguring it to either Non-Slot 0 or automatic configuration. Neglecting to do this could result in damage to the device, the VXIbus backplane, or both.*

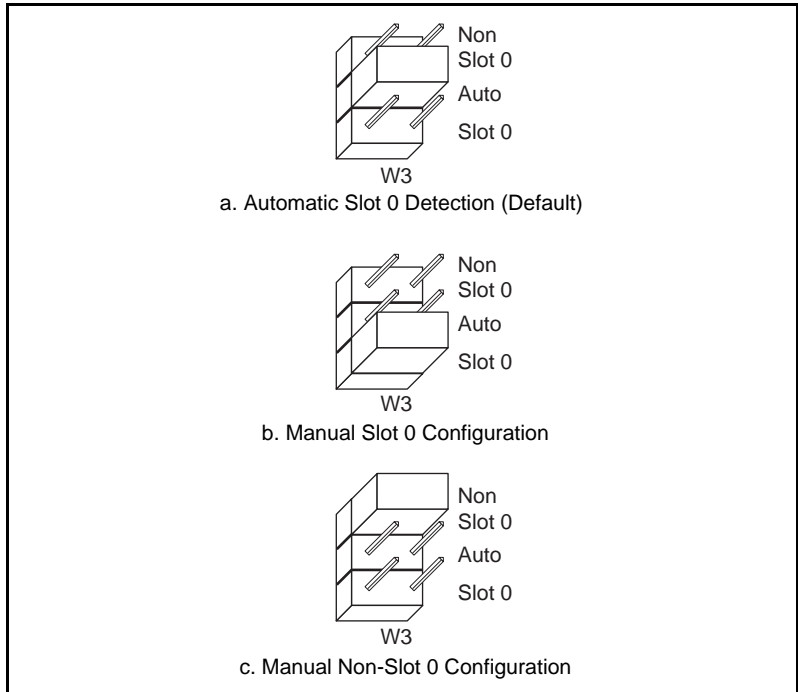

**Figure 5-3.** VXIbus Slot Configuration

When the VXI-MXI-2/B is installed in Slot 0, it becomes the VMEbus System Controller. In this role, it has VMEbus Data Transfer Bus Arbiter circuitry that accepts bus requests on all four VMEbus request levels, prioritizes the requests, and grants the bus to the highest priority requester. As VMEbus System Controller, the VXI-MXI-2/B also drives the 16 MHz VMEbus system clock using an onboard 16 MHz oscillator.

As required by the VXIbus specification, the VXI-MXI-2/B drives the 10 MHz signal CLK10 on a differential ECL output when installed in Slot 0. When not installed in Slot 0, the VXI-MXI-2/B only receives the CLK10 signal.

## VXIbus CLK10 Routing

When you install it in Slot 0 of your mainframe, the VXI-MXI-2/B supplies the VXIbus CLK10 signal. The VXI-MXI-2/B can use three different sources to generate this signal: an onboard oscillator, the external CLK SMB connector, and the MXIbus CLK10 signal. Use the three-position jumper W1 to select these options, as shown in Figure 5-4.

Notice that Figures 5-4b and 5-4c also show switches S7 and S1, respectively. You must configure these switches as shown when using the corresponding CLK10 source setting of W1.

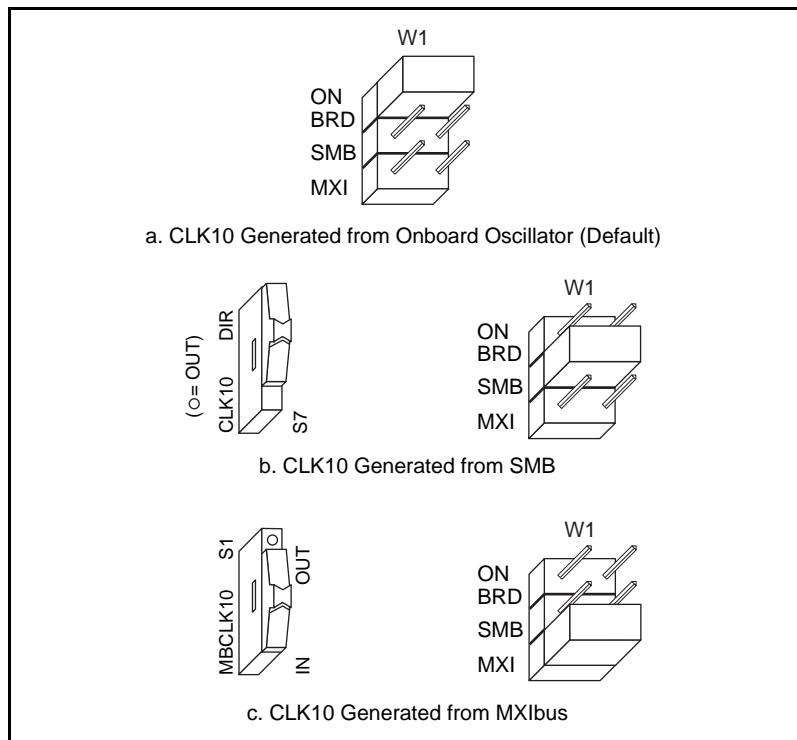

**Figure 5-4.** VXIbus CLK10 Routing

You can also configure the VXI-MXI-2/B to drive the external CLK SMB signal from the VXIbus CLK10 signal. Switch S7 controls whether the VXI-MXI-2/B drives or receives the external CLK SMB signal. If you change the S7 setting to drive CLK10 out the external

CLK10 SMB connector, do not set the W1 jumper to receive the SMB CLK10 signal; instead use the settings shown in either Figure 5-4a or Figure 5-4c as appropriate.

When you set switch S7 so that the VXI-MXI-2/B receives the SMB CLK10 signal, you have the option to add a 50  $\Omega$  termination to the signal by setting switch S6. S6 is unused—its setting does not matter—when S7 is configured to drive the external CLK SMB signal.

You can use an additional switch, S3, to control the polarity of the external CLK SMB signal when S7 is configured to drive it. S3 is unused—its setting does not matter—when S7 is configured to receive the external CLK SMB signal.

Figure 5-5 shows four configuration settings for the VXI-MXI-2/B. Figure 5-5a shows the default configuration, which is for driving the inverted external CLK SMB. Use the settings of Figure 5-5b to drive the noninverted external CLK SMB signal. Figure 5-5c illustrates the setting for receiving the external CLK SMB signal. Finally, you can configure the switches as shown in Figure 5-5d to receive the external CLK SMB signal with a 50  $\Omega$  termination.



**Note:**

*The settings of any switches shown with this pattern (  ) have no bearing on the configuration described in any of the following figures.*

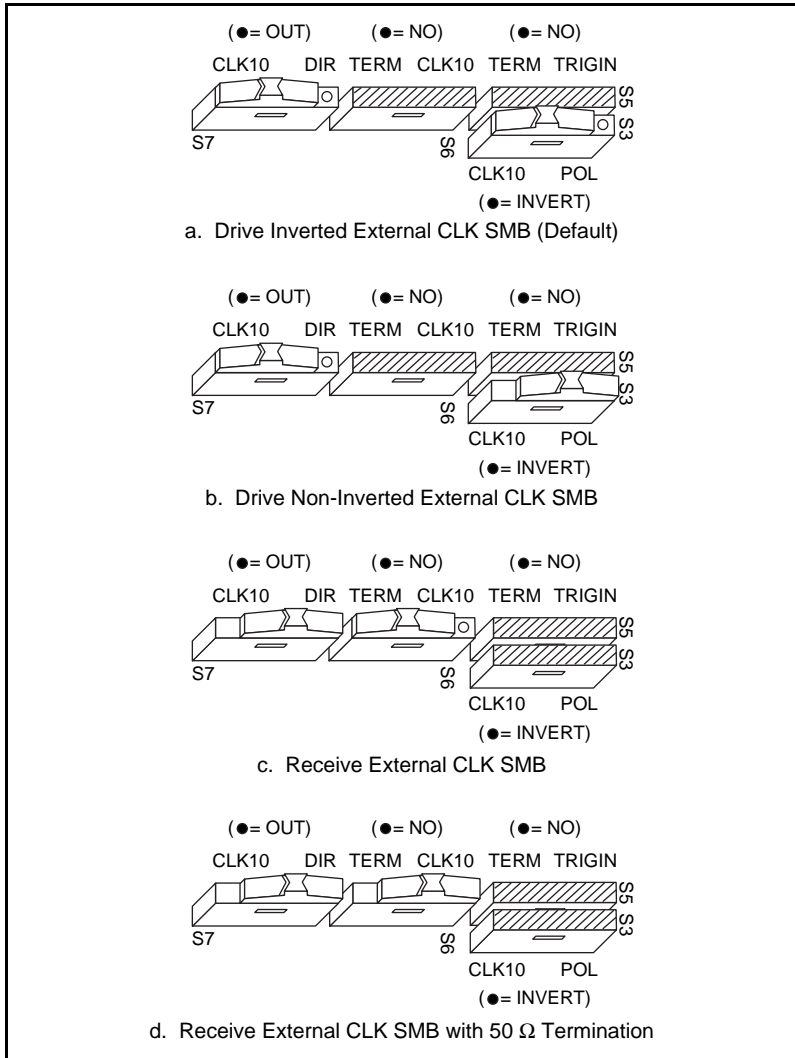

**Figure 5-5.** SMB CLK10 Settings

The VXI-MXI-2/B can also drive or receive the MXIbus CLK10 signal. Switch S1 controls whether the VXI-MXI-2/B drives MXIbus CLK10 from the VXIbus CLK10 or receives MXIbus CLK10. As shown in Figure 5-4c, if W1 is configured to use the MXIbus CLK10 to generate the VXIbus CLK10 signal, switch S1 must be configured to receive MXIbus CLK10. This is shown again in Figure 5-6a.

If you change the S1 setting to drive CLK10 out the MXIbus, do not set the W1 jumper setting to receive the MXIbus CLK10; instead use the settings shown in Figure 5-4a or 5-4b as appropriate.



**Caution:** *Do not configure more than one MXIbus device to drive the MXIbus CLK10. Having a second device driving MXIbus CLK10 could damage the device.*

Figure 5-6 shows the configuration settings for receiving and driving MXIbus CLK10, respectively.

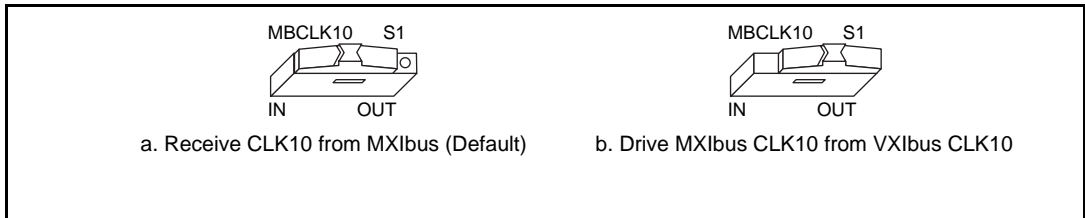

**Figure 5-6.** Receiving or Driving MXIbus CLK10

## Trigger Input Termination

You can use switch S5 to terminate the external trigger input SMB with 50  $\Omega$ . Figure 5-7a shows the default setting for a nonterminated trigger input SMB. Use the setting of Figure 5-7b to terminate the trigger input SMB.

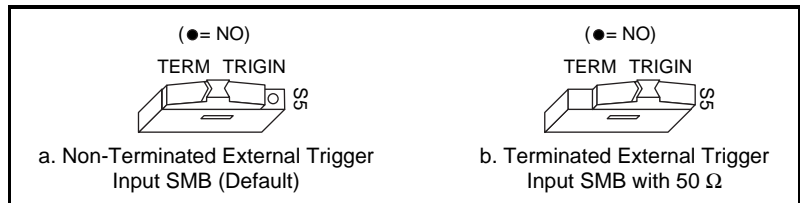

**Figure 5-7.** SMB Trigger Input Termination

## MXIbus Termination

The first and last MXIbus devices connected to the MXIbus—whether using a single MXI-2 cable or daisy-chained MXI-2 cables—must terminate the MXIbus. Any MXIbus devices in the middle of a MXIbus daisy chain must *not* terminate the MXIbus.

The VXI-MXI-2/B automatically senses whether it is at either end of the MXIbus cable to terminate the MXIbus. You can manually control MXIbus termination by defeating the automatic circuitry. Use switches 3 and 4 of the four-position switch at location U21 to control whether MXIbus termination is automatic (Figure 5-8a), on (Figure 5-8b), or off (Figure 5-8c). The settings of switches 1 and 2 have no effect on MXIbus termination.

Use switch 3 to select whether the VXI-MXI-2/B automatically controls termination of the MXIbus. Notice in Figure 5-8a that switch 4 has no effect when switch 3 is set for automatic MXIbus termination.

If you want to control termination manually, you must turn off switch 3. You can then use switch 4 to manually control whether to terminate the MXIbus.

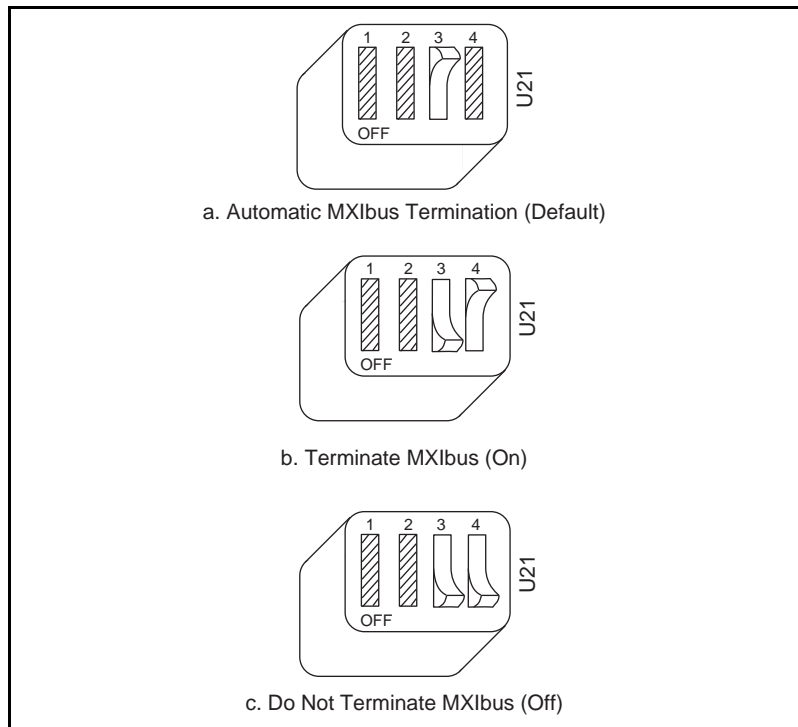

**Figure 5-8.** MXIbus Termination



## Configuration EEPROM

The VXI-MXI-2/B has an onboard EEPROM, which stores default register values that are loaded at power-on. The EEPROM is divided into two halves—a factory-configuration half, and a user-configuration half—so you can modify the user-configurable half while the factory-configured half stores a back-up of the factory settings.

Use switches 1 and 2 of the four-position switch at location U21 to control the operation of the EEPROM. The Restore Factory Configuration switch (switch 1) causes the VXI-MXI-2/B to boot from the factory-configured half instead of the user-modified settings. This is useful in the event that the user-configured half of the EEPROM becomes corrupted in such a way that the VXI-MXI-2/B boots to an unusable state.

The Change Factory Configuration switch (switch 2) lets you change the factory-default configuration settings by permitting writes to the factory settings section of the EEPROM. This switch serves as a safety measure and is not needed under normal circumstances. When this switch is off (its default setting), the factory configuration of the EEPROM is protected, so any writes to the factory area are ignored. The factory area is protected regardless of the setting of switch 1.

Figure 5-9 shows the configuration settings for EEPROM operation. The settings of switches 3 and 4 have no effect on EEPROM configuration.

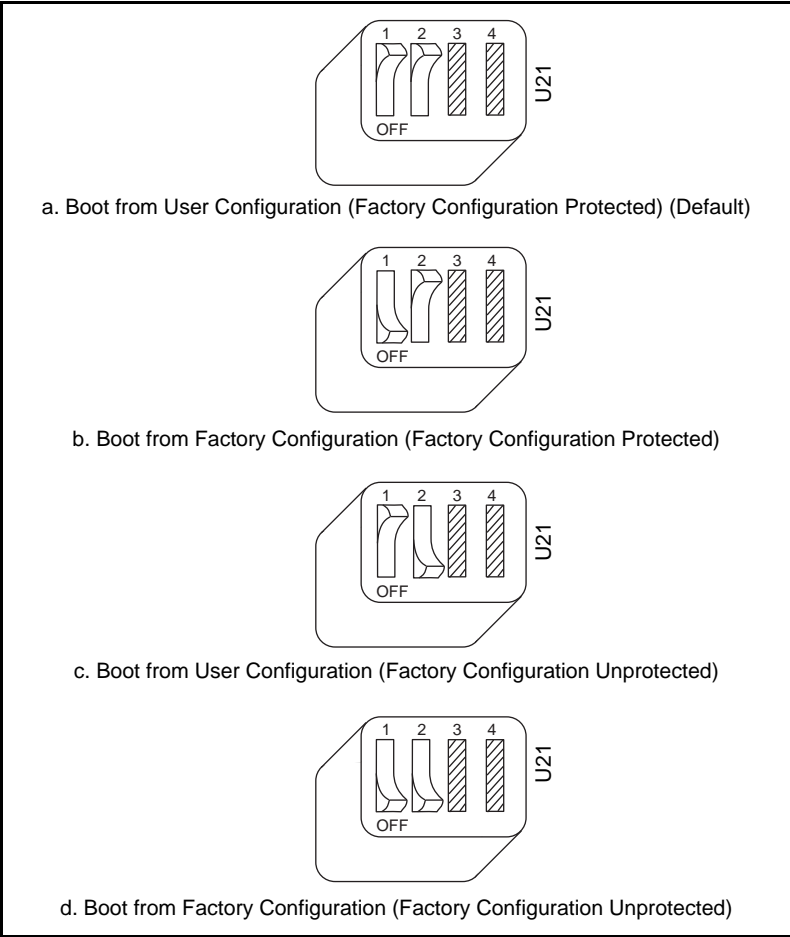
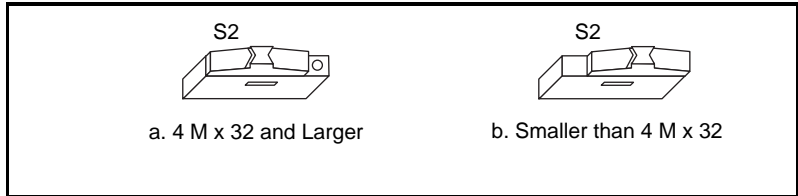

**Figure 5-9.** EEPROM Operation

## Onboard DRAM

The VXI-MXI-2/B can accommodate up to two 1.35 in. 72-pin DRAM SIMMs. Table 5-1 lists the SIMMs you can use. You can use 32-bit or 36-bit SIMMs, because DRAM parity is not required. Because the VXI-MXI-2/B supports only one organization at a time, all SIMMs installed must be of the same type. Use Bank 0 first when installing the SIMMs, and use Bank 1 when you need to install a second, matching SIMM. As shown in Table 5-1, you can install up to 64 MB. The VXI-MXI-2/B supports DRAM speeds of 80 ns or faster.

Use switch S2 to select the size of each SIMM. If the SIMMs are 4 M × 32 or larger, set S2 to the OFF setting as shown in Figure 5-10a. For SIMMs *smaller* than 4 M × 32, use the ON setting as shown in Figure 5-10b.



**Figure 5-10.** SIMM Size Configuration

Refer to Table 5-1 for how to adjust the switch (ON or OFF) for all supported DRAM configurations. Many of the DRAM options are available from National Instruments.



**Note:**

*After installing DRAM on the VXI-MXI-2/B, you need to enable the memory through the T&M Explorer utility.*

**Table 5-1.** VXI-MXI-2/B DRAM Configurations

Bank 0	Bank 1	Total DRAM	National Instruments Option?	Switch Setting of S6
—	—	0	—	—
256 K × 32 or 256 K × 36	—	1 MB	—	ON
256 K × 32 or 256 K × 36	256 K × 32 or 256 K × 36	2 MB	—	ON
512 K × 32 or 512 K × 36	—	2 MB	—	ON
512 K × 32 or 512 K × 36	512 K × 32 or 512 K × 36	4 MB	—	ON
1 M × 32 or 1 M × 36	—	4 MB	YES	ON
1 M × 32 or 1 M × 36	1 M × 32 or 1 M × 36	8 MB	—	ON

**Table 5-1.** VXI-MXI-2/B DRAM Configurations (Continued)

Bank 0	Bank 1	Total DRAM	National Instruments Option?	Switch Setting of S6
2 M × 32 or 2 M × 36	—	8 MB	YES	ON
2 M × 32 or 2 M × 36	2 M × 32 or 2 M × 36	16 MB	—	ON
4 M × 32 or 4 M × 36	—	16 MB	YES	OFF
4 M × 32 or 4 M × 36	4 M × 32 or 4 M × 36	32 MB	—	OFF
8 M × 32 or 8 M × 36	—	32 MB	YES	OFF
8 M × 32 or 8 M × 36	8 M × 32 or 8 M × 36	64 MB	YES	OFF



**Caution:** *If you install DRAM into the VXI-MXI-2/B, do not attempt to use the first 4 KB of memory space. This 4 KB space maps to the registers on the VXI-MXI-2/B and does not access onboard DRAM. Accessing this region will cause your VXI-MXI-2/B to behave incorrectly.*

## VXIbus Local Bus

If you install more than one VXI-MXI-2/B in a single VXIbus mainframe, you must configure the boards to use the local bus. The VXI-MXI-2/B uses the local bus to pass a signal to the other VXI-MXI-2 modules in the mainframe to disable the VMEbus bus timeout unit (BTO) during cycles that map to the MXIbus. Because the local bus is used, you must install all VXI-MXI-2/B modules for a single mainframe in adjacent slots.

Use the jumper block at W2 to select the module's position in relation to any other VXI-MXI-2/B module in the mainframe.

Figure 5-11 shows four configuration settings for a VXI-MXI-2/B. Figure 5-11a illustrates the default setting, which is for a single VXI-MXI-2/B in a mainframe. Use the setting in Figure 5-11b for the VXI-MXI-2/B located to the left of all others (lowest-numbered slot).

Figure 5-11c shows the setting to use if the VXI-MXI-2/B is between two others. Use the setting of Figure 5-11d for the VXI-MXI-2/B located to the right of all others (highest-numbered slot).

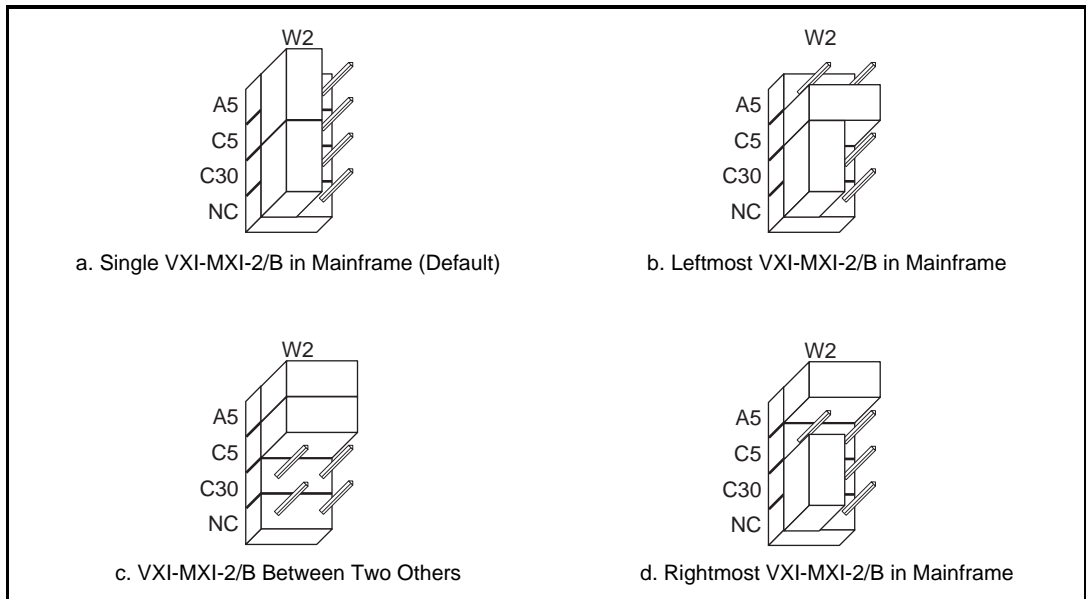

Figure 5-11. VXIbus Local Bus Configuration

## Install the VXI-MXI-2/B

This section contains general installation instructions for the VXI-MXI-2/B. Consult the user manual or technical reference manual of your VXIbus mainframe for specific instructions and warnings.



**Note:** *If you install the VXI-MXI-2/B in a VME chassis, ensure that no other devices drive the VMEbus user-defined pins—rows A and C of P2/J2.*

1. Plug in your mainframe before installing the VXI-MXI-2/B. The power cord grounds the mainframe and protects it from electrical damage while you install the module.



**Warning:** *To protect both yourself and the mainframe from electrical hazards, leave the mainframe off until you finish installing the VXI-MXI-2/B module.*

2. Remove or open any doors or covers blocking access to the mainframe slots.



**Caution:** *If the VXI-MXI-2/B is not configured for automatic Slot 0 detection, be certain that the slot you select in your VXIbus mainframe matches the VXI-MXI-2/B configuration as either a Slot 0 device or a Non-Slot 0 device. If you install your VXI-MXI-2/B into a slot that does not correspond with the jumper setting, you risk damage to the VXI-MXI-2/B, the VXIbus backplane, or both.*

3. Insert the VXI-MXI-2/B in the slot you have selected by aligning the top and bottom of the board with the card-edge guides inside the mainframe. Slowly push the VXI-MXI-2/B straight into the slot until its plug connectors rest on the backplane receptacle connectors. Using slow, evenly distributed pressure, press the VXI-MXI-2/B straight in until it seats in the expansion slot. The front panel of the VXI-MXI-2/B should be even with the front panel of the mainframe.
4. Tighten the retaining screws on the top and bottom edges of the front panel.
5. Check the installation.
6. Connect the cables as described in the following section before restoring power.
7. Replace or close any doors or covers to the mainframe.

## Connect the MXIbus Cable

---

There are two basic types of MXI-2 cables. MXI-2 cables can have either a single connector on each end or a single connector on one end and a double connector on the other end.

Connect the labeled end of the cable to the MXI-2 device that will be the MXIbus System Controller. Connect the other end of the cable to the other device. Be sure to tighten the screw locks to ensure proper pin connection.

Figure 5-12 shows the correct cabling for a VXI system containing a PCI-MXI-2 board in a PCI-based computer cabled to a VXI-MXI-2/B module residing in Slot 0 of a VXIbus mainframe. The cabling scheme is the same for a PXI-8320 board installed in a PXI/CompactPCI chassis. Notice that you can expand your system to include other devices by using an additional MXI-2 cable. However, in such a case the first cable must have a double connector on one end. You can use a cable with a single connector on each end to connect the last device on the MXIbus.

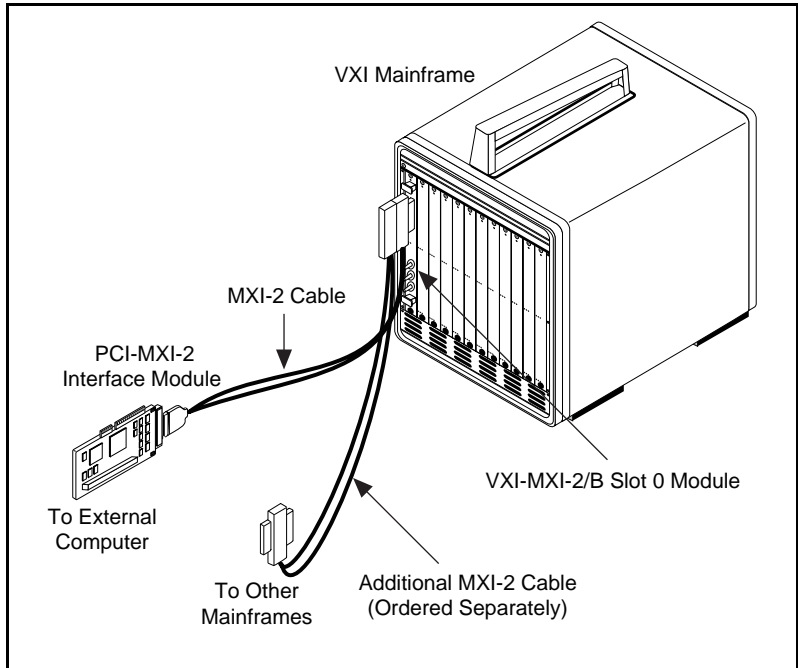

**Figure 5-12.** MXI-2 Cable Configuration Using a PCI-MXI-2 and a VXI-MXI-2/B

When you have properly connected the MXI-2 cable, power on the VXIbus mainframe and then the computer.



**Note:**

*Always turn on the mainframe first. Doing so makes it possible for your external computer to access the VXI boards in the mainframe upon startup.*

# VME-MXI-2 Configuration and Installation

---

Chapter

6

This chapter contains the instructions to configure and install the VME-MXI-2 module. This chapter applies only if your kit contains a VME-MXI-2. If you ordered the VXI kit, you should refer to Chapter 4, *VXI-MXI-2 Configuration and Installation*, or Chapter 5, *VXI-MXI-2/B Configuration and Installation*.

Configuring the VME-MXI-2 is optional. A typical configuration can use the default settings.



**Caution:** *Electrostatic discharge can damage several components on your VME-MXI-2 module. To avoid such damage in handling the module, touch the antistatic plastic package to a metal part of your VMEbus chassis before removing the VME-MXI-2 from the package.*

## Configure the VME-MXI-2

---

This section describes how to configure the following options on the VME-MXI-2.

- VMEbus A16 base address
- MXIbus termination
- Configuration EEPROM
- Onboard DRAM
- VME-MXI-2 intermodule signaling

The VME-MXI-2 automatically detects if it is located in the first slot of the chassis to perform the VMEbus System Controller functions. It is not necessary to configure the VMEbus System Controller option. You can install the module in any slot of a VMEbus chassis.

Figure 6-1 shows the VME-MXI-2. The drawing shows the location and factory-default settings of the configuration switches and jumpers on the module.



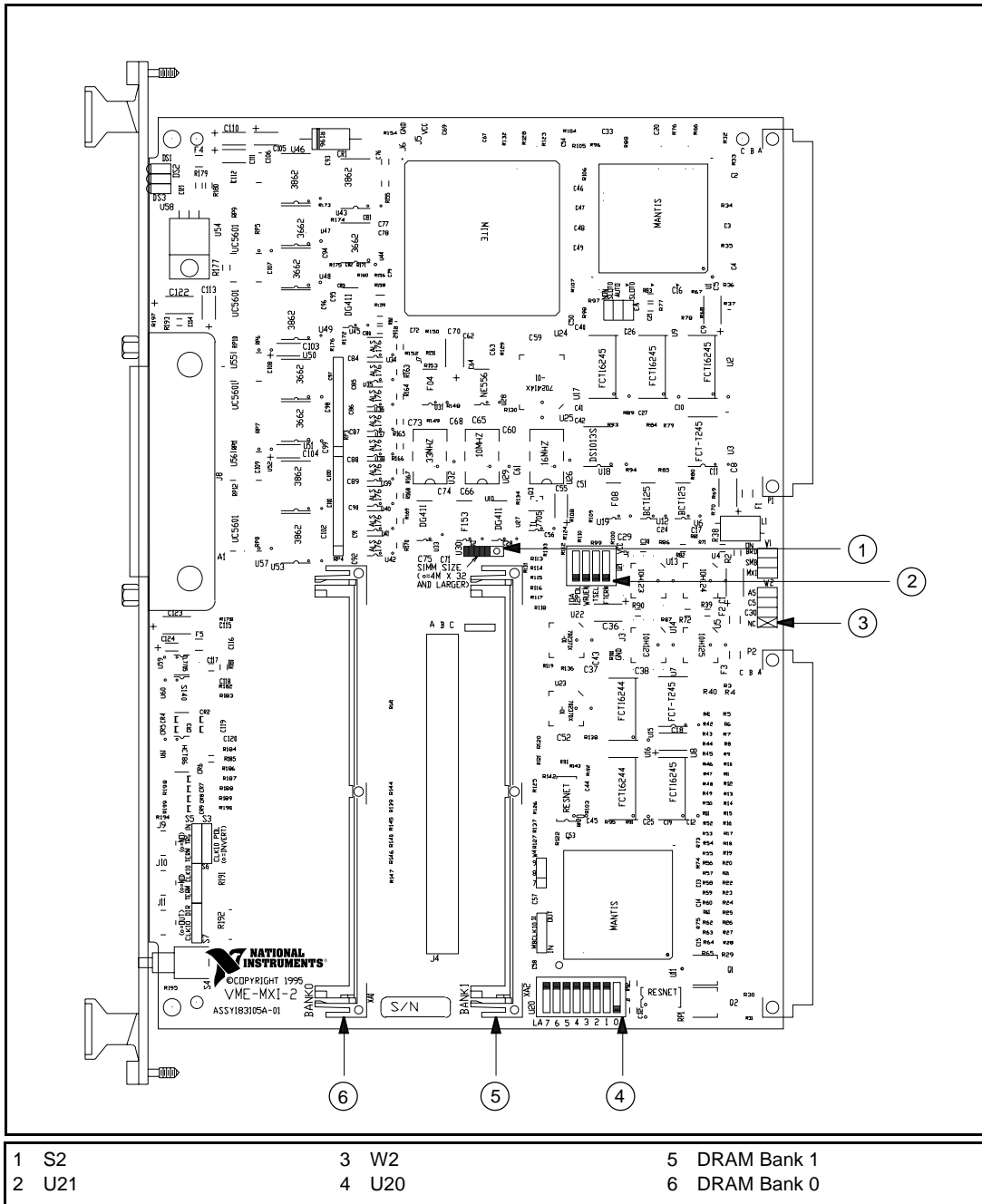

Figure 6-1. VME-MXI-2 Parts Locator Diagram

## Front Panel Features

The VME-MXI-2 has the following front panel features.

- Three front panel LEDs
  - **SYSFAIL** LED indicates that the VMEbus SYSFAIL line is asserted.
  - **MXI** LED indicates when the VME-MXI-2 is accessed from the MXIbus.
  - **VME** LED indicates when the VME-MXI-2 is accessed from the VMEbus.
- MXIbus connector
- System reset push-button

## VMEbus A16 Base Address

The VME-MXI-2 requires 64 B (bytes) of A16 space for its configuration registers. It uses the *logical address* scheme of the VXIbus specification, in which each device is assigned an 8-bit value called the logical address. This logical address allocates 64 B of space to the device within the upper quarter of A16 space. The VME-MXI-2 cannot be configured to locate its registers in the lower three quarters of A16 space. The A16 base address of the VME-MXI-2 is address lines 15 and 14 high with address lines 13 through 6 matching the logical address of the VME-MXI-2, and address lines 5 through 0 low. In other words, the A16 base address of the VME-MXI-2 module's 64 B register set is as calculated below:

$$\text{base address} = \text{C000 hex} + (\text{logical address}) * 40 \text{ hex}$$

The factory-default logical address for the VME-MXI-2 is 1, which locates the registers in the range C040 hex to C07F hex. You can change the logical address of the VME-MXI-2 by changing the setting of the 8-bit DIP switch at location designator U20. The ON position of the DIP switch corresponds to a logic value of 0, and the OFF position corresponds to a logic value of 1. Allowable logical addresses for the VME-MXI-2 range from 1 to 254 (hex FE).

Verify that no other devices in your system use the A16 address space for the VME-MXI-2. If possible, configure all other VMEbus A16 devices to be located within the lower three quarters of A16 space. Also, when setting base addresses, keep in mind the grouping requirements

set by the system hierarchy. See *VXI-6, VXIbus Mainframe Extender Specification*, for more information on setting base addresses on a multiframe hierarchy.

Figure 6-2 shows switch settings for A16 base address hex C040 and F000.

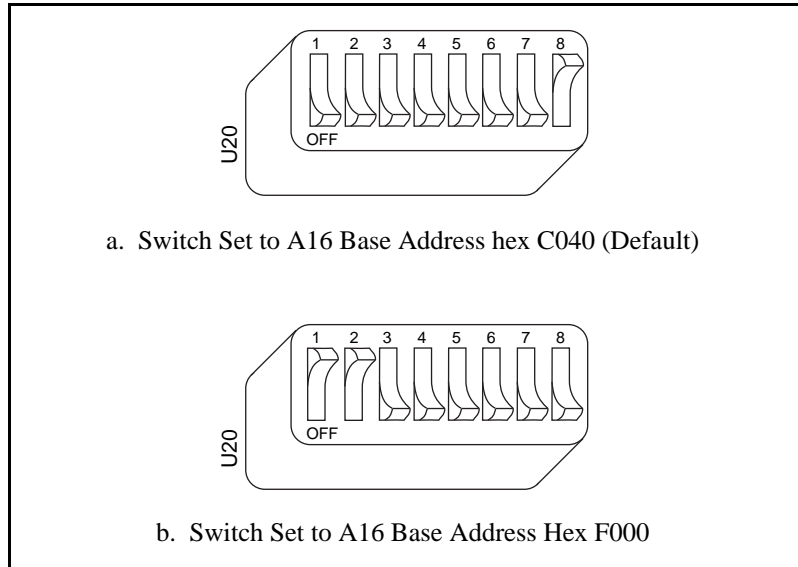

**Figure 6-2.** Base Address Selection

## MXIbus Termination

The first and last MXIbus devices connected to the MXIbus—whether using a single MXI-2 cable or daisy-chained MXI-2 cables—must terminate the MXIbus. Any MXIbus devices in the middle of a MXIbus daisy chain must *not* terminate the MXIbus.

The VME-MXI-2 automatically senses if it is at either end of the MXIbus cable to terminate the MXIbus. You can manually control MXIbus termination by defeating the automatic circuitry. Use switches 3 and 4 of the four-position switch at location U21 to control whether MXIbus termination is automatic (Figure 6-3a), on (Figure 6-3b), or off (Figure 6-3c). The settings of switches 1 and 2 have no effect on MXIbus termination.

Use switch 3 to select whether you want the VME-MXI-2 to automatically control termination of the MXIbus. Use switch 4 to manually control whether to terminate the MXIbus when automatic termination is turned off. Switch 4 has no effect when switch 3 is set for automatic MXIbus termination; you must turn off automatic termination if you want to manually control termination.

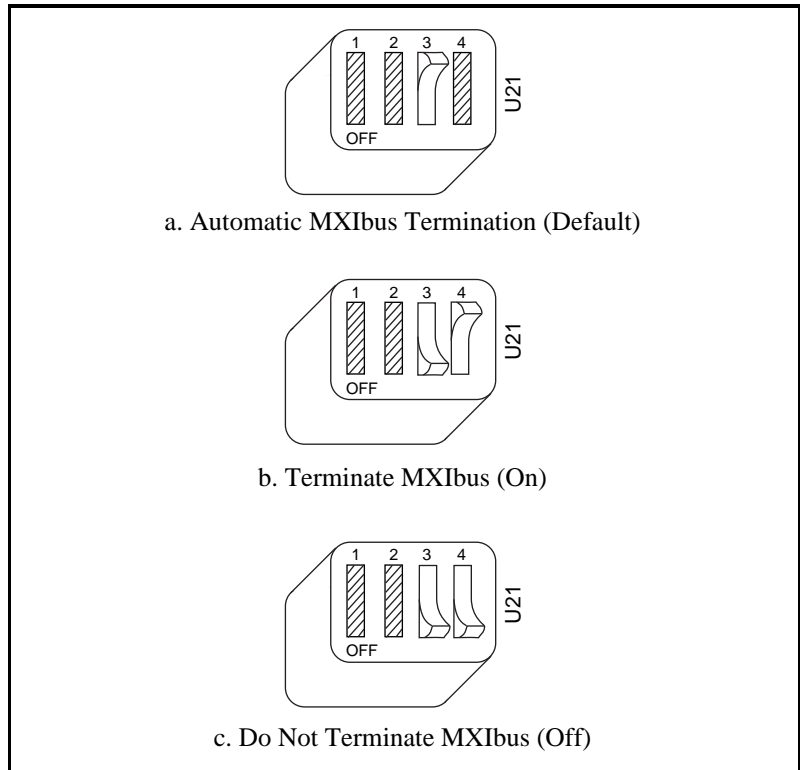

**Figure 6-3.** MXIbus Termination

## Configuration EEPROM

The VME-MXI-2 has an onboard EEPROM, which stores default register values that are loaded at power-on. The EEPROM is divided into two halves—a factory-configuration half, and a user-configuration half—so you can modify the user-configurable half while the factory-configured half stores a back-up of the default user settings.

Use switches 1 and 2 of the four-position switch at location U21 to control the operation of the EEPROM. The Restore Factory Configuration switch (switch 1) causes the VME-MXI-2 to boot from the factory-configured half instead of the user-modified settings. This is useful in the event that the user-configured half of the EEPROM becomes corrupted in such a way that the VME-MXI-2 boots to an unusable state.

The Change Factory Configuration switch (switch 2 of U21) lets you change the factory-default configuration settings by permitting writes to the factory settings section of the EEPROM. This switch serves as a safety measure and is not needed under normal circumstances. When this switch is off (its default setting), the factory configuration of the EEPROM is protected so any writes to the factory area are ignored. The factory area is protected regardless of the setting of switch 1 of U21.

Figure 6-4 shows the configuration settings for EEPROM operation. The settings of switches 3 and 4 have no effect on EEPROM configuration.

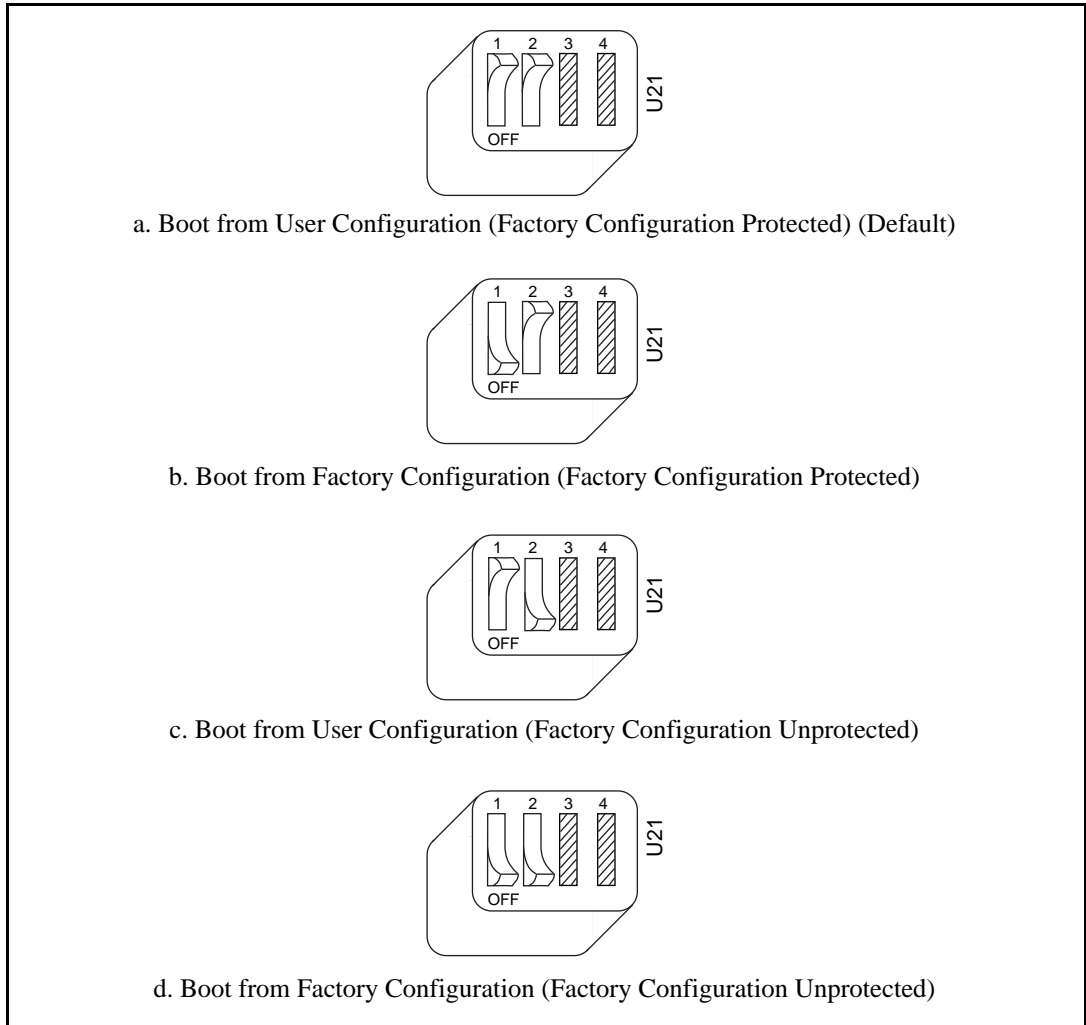

Figure 6-4. EEPROM Operation

## Onboard DRAM

The VME-MXI-2 can accommodate up to two 1.35 in. 72-pin DRAM SIMMs. Table 6-1 lists the SIMM types you can use. You can use 32-bit or 36-bit SIMMs because DRAM parity is not required. Because the VME-MXI-2 supports only one organization at a time, all SIMMs installed must be of the same type. Use Bank 0 first when installing the SIMMs, and use Bank 1 when you need to install a second, matching

SIMM. As shown in Table 6-1, you can install up to 64 MB. The VME-MXI-2 supports DRAM speeds of 80 ns or faster.

Use switch S2 to select the size of each SIMM. If the SIMMs are 4 M x 32 or larger, set S2 to the OFF setting as shown in Figure 6-5a. For SIMMs *smaller* than 4 M x 32, use the ON setting as shown in Figure 6-5b.

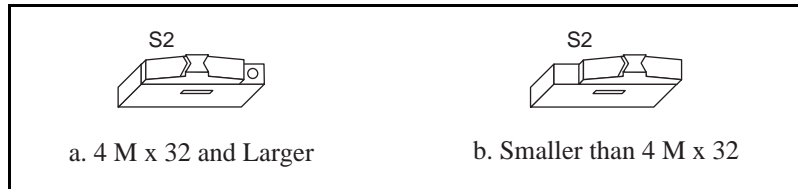

**Figure 6-5.** SIMM Size Configuration

Refer to Table 6-1 for how to adjust the switch (ON or OFF) for all supported DRAM configurations. Many of the DRAM options are available from National Instruments.



**Note:** *After installing DRAM on the VME-MXI-2, you need to enable the memory through the T&M Explorer utility.*

**Table 6-1.** VME-MXI-2 DRAM Configurations

Bank 0	Bank 1	Total DRAM	National Instruments Option?	Switch Setting of S6
—	—	0	—	—
256 K x 32 or 256 K x 36	—	1 MB	—	ON
256 K x 32 or 256 K x 36	256 K x 32 or 256 K x 36	2 MB	—	ON
512 K x 32 or 512 K x 36	—	2 MB	—	ON
512 K x 32 or 512 K x 36	512 K x 32 or 512 K x 36	4 MB	—	ON
1 M x 32 or 1 M x 36	—	4 MB	YES	ON

**Table 6-1.** VME-MXI-2 DRAM Configurations (Continued)

<b>Bank 0</b>	<b>Bank 1</b>	<b>Total DRAM</b>	<b>National Instruments Option?</b>	<b>Switch Setting of S6</b>
1 M x 32 or 1 M x 36	1 M x 32 or 1 M x 36	8 MB	—	ON
2 M x 32 or 2 M x 36	—	8 MB	YES	ON
2 M x 32 or 2 M x 36	2 M x 32 or 2 M x 36	16 MB	—	ON
4 M x 32 or 4 M x 36	—	16 MB	YES	OFF
4 M x 32 or 4 M x 36	4 M x 32 or 4 M x 36	32 MB	—	OFF
8 M x 32 or 8 M x 36	—	32 MB	YES	OFF
8 M x 32 or 8 M x 36	8 M x 32 or 8 M x 36	64 MB	YES	OFF



**Caution:** *If you install DRAM into the VME-MXI-2, do not attempt to use the first 4 KB of memory space. This 4 KB space maps to the registers on the VME-MXI-2 and does not access onboard DRAM. Accessing this region will cause your VME-MXI-2 to behave incorrectly.*

## VME-MXI-2 Intermodule Signaling

If you install more than one VME-MXI-2 in a single VMEbus chassis, you must select a user-defined pin for use by the VME-MXI-2. The VME-MXI-2 modules use this signal to disable the bus timeout unit(s) on the other VME-MXI-2 modules during VMEbus accesses that map to the MXIbus. This is done because the MXIbus bus timeout unit should be the sole timer of any MXIbus access. Since bus timeout units on other VMEbus modules cannot monitor this signal, they should be permanently disabled. If it is not possible to disable a module's bus timeout unit, configure it to the highest setting to give MXIbus accesses as much time as possible.

You can choose from three user-defined pins on J2/P2. The pin you select must be based on the VMEbus backplane between all slots that



will have a VME-MXI-2 installed. Use jumper W2 to select pin A5, C5, or C30 of J2/P2, as shown in Figure 6-6.

The fourth position on the jumper is the factory-default setting, which does not connect the VME-MXI-2 to any user-defined pin. Use this option only if you are installing a single VME-MXI-2 in a chassis.

Figure 6-6 shows the four intermodule signaling settings.

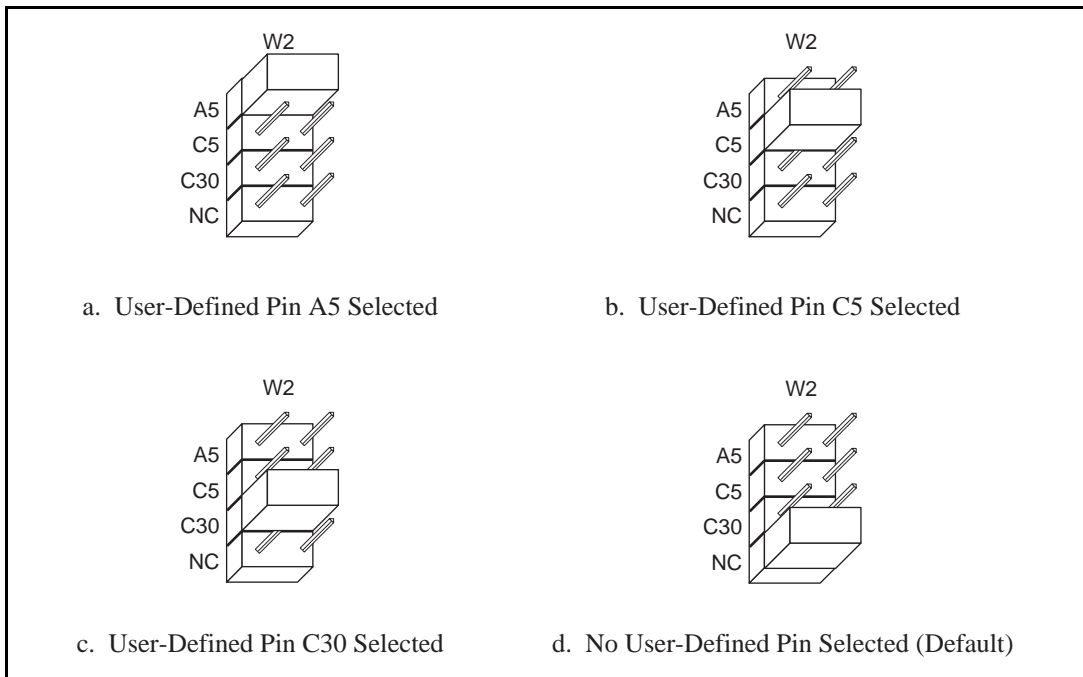

**Figure 6-6.** VME-MXI-2 Intermodule Signaling Settings

## Install the VME-MXI-2

This section contains general installation instructions for the VME-MXI-2. Consult your VMEbus mainframe user manual or technical reference manual for specific instructions and warnings.

1. Plug in your mainframe before installing the VME-MXI-2. The power cord grounds the mainframe and protects it from electrical damage while you are installing the module.



**Warning:** *To protect both yourself and the mainframe from electrical hazards, leave the mainframe off until you finish installing the VME-MXI-2 module.*

2. Remove or open any doors or covers blocking access to the mainframe slots.
3. Insert the VME-MXI-2 in the slot you have selected by aligning the top and bottom of the board with the card-edge guides inside the mainframe. Slowly push the VME-MXI-2 straight into the slot until its plug connectors rest on the backplane receptacle connectors. Using slow, evenly distributed pressure, press the VME-MXI-2 straight in until it seats in the expansion slot. The front panel of the VME-MXI-2 should be even with the front panel of the mainframe.
4. Tighten the retaining screws on the top and bottom edges of the front panel.
5. Check the installation.
6. Connect the cables as described in the following section before restoring power.
7. Replace or close any doors or covers to the mainframe.

## Connect the MXIbus Cable

---

There are two basic types of MXI-2 cables. MXI-2 cables can have either a single connector on each end or a single connector on one end and a double connector on the other end.

Connect the labeled end of the cable to the MXI-2 device that will be the MXIbus System Controller. Connect the other end of the cable to the other device. Be sure to tighten the screw locks to ensure proper pin connection.

Figure 6-7 shows the correct cabling for a VME system containing a PCI-MXI-2 board in a PCI-based computer cabled to a VME-MXI-2 module residing in Slot 1 of a VMEbus mainframe. The cabling scheme is the same for a PXI-8320 board installed in a PXI/CompactPCI chassis. Notice that you can expand your system to include other devices by using an additional MXI-2 cable. However, in such a case the first cable must have a double connector on one end. You can use a cable with a single connector on each end to connect the last device on the MXIbus.

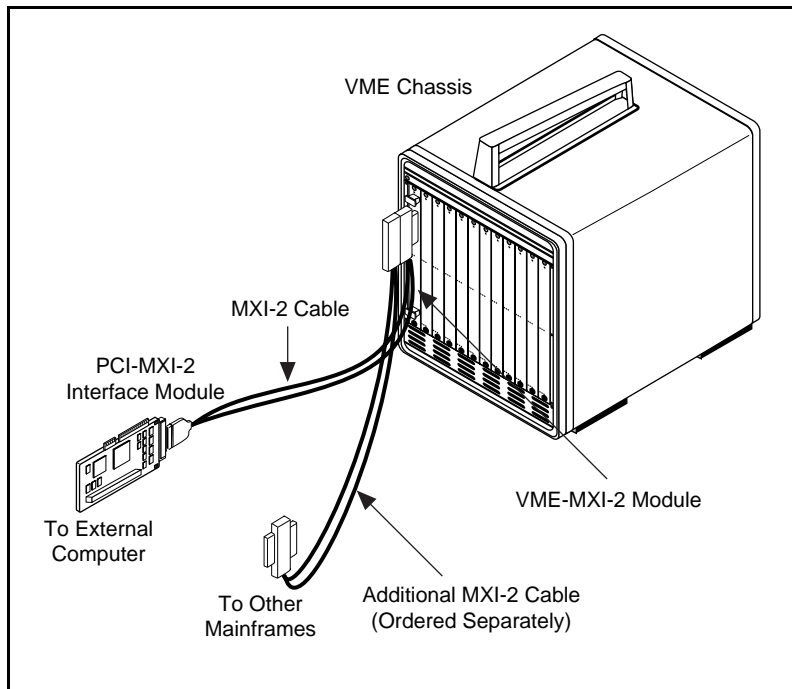

**Figure 6-7.** MXI-2 Cable Configuration Using a PCI-MXI-2 and a VME-MXI-2

When you have properly connected the MXI-2 cable, power on the VMEbus mainframe and then the computer.



**Note:**

*Always turn on the mainframe first. Doing so makes it possible for your external computer to access the VME boards in the mainframe upon startup.*

# Specifications

---

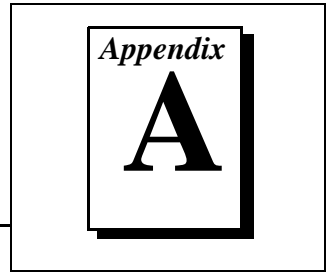

This appendix lists various module specifications of the PCI-MXI-2, PXI-8320, VXI-MXI-2 (C-size and B-size), and VME-MXI-2, such as physical dimensions and power requirements.

## PCI-MXI-2

This section lists the specifications for the PCI-MXI-2 module.

### MXIbus Capability Descriptions

- Master-mode A32, A24, and A16 addressing
- Master-mode block transfers and synchronous block transfers
- Slave-mode A32, A24, and A16 addressing
- Slave-mode block transfers and synchronous block transfers
- Master-mode D32, D16, and D08 data sizes
- Slave-mode D32, D16, and D08 data sizes
- Optional MXIbus System Controller
- Can be a fair MXIbus requester
- Can lock the MXIbus for indivisible transfers
- Can terminate the MXIbus
- MXIbus master retry support
- MXIbus slave retry support
- Interrupt handler for levels 7 to 1
- Interrupt requester for levels 7 to 1
- MXIbus D32, D16, D08(O) interrupt handler
- MXIbus D32, D16, D08(O) interrupter
- Release on Acknowledge or Register Access interrupter
- MXIbus bus timer (programmable limit)
- Automatic MXIbus System Controller detection

## PCI Functionality

Characteristic	Specification
PCI Initiator (Master) Capability	Supported
PCI Target (Slave) Capability	Supported
Data Path	32 bits
Card Voltage/Type	5 V only; 32-bit half-size card
Parity Generation/Checking, Error Reporting	Supported
Target Decode Speed	Medium (one clock)
Target Fast-Back-to-Back Capability	Supported
Resource Locking	Supported as a master and slave
PCI Interrupts	Interrupts passed on INTA# signal
Base Address Registers	BAR 0 dedicated to local registers BAR 1–3 size configurable from 256 B to 4 GB
Expansion ROM	8 KB
PCI Master Performance (Ideal Maximum)	132 MB/s (16 Dwords maximum)
PCI Slave Performance (Ideal Maximum)	33 MB/s (to local registers)

## Environmental

Characteristic	Specification
Temperature	0° to 55° C operating; –40° to 85° C storage
Relative Humidity	0% to 95% noncondensing, operating; 0% to 95% noncondensing, storage
EMI	FCC Class A Verified

## Requirements

Characteristic	Specification
Memory Space	32 KB minimum, programmable

## Physical

Characteristic	Specification
Board Dimensions	174.63 by 106.68 mm (6.875 by 4.2 in.)
Connectors	Single fully implemented MXI-2 connector
Slot Requirements	Single PCI slot
MTBF	157,172 hours
Weight	0.18 Kg (0.4 lb) typical (no DRAM installed)

## Electrical

Source	Typical	Direct Current (Max)
+5 VDC	2.2 A	3.5 A

## Performance

MXI Transfer Rate	
Peak	33 MB/s
Sustained	23 MB/s

# PXI-8320

---

This section lists the specifications for the PXI-8320 module.

## MXIbus Capability Descriptions

- Master-mode A32, A24, and A16 addressing
- Master-mode block transfers and synchronous block transfers
- Slave-mode A32, A24, and A16 addressing
- Slave-mode block transfers and synchronous block transfers
- Master-mode D32, D16, and D08 data sizes
- Slave-mode D32, D16, and D08 data sizes
- Optional MXIbus System Controller
- Can be a fair MXIbus requester
- Can lock the MXIbus for indivisible transfers
- Can terminate the MXIbus
- MXIbus master retry support
- MXIbus slave retry support
- Interrupt handler for levels 7 to 1
- Interrupt requester for levels 7 to 1
- MXIbus D32, D16, D08(O) interrupt handler
- MXIbus D32, D16, D08(O) interrupter
- Release on Acknowledge or Register Access interrupter
- MXIbus bus timer (programmable limit)
- Automatic MXIbus System Controller detection

## PCI Functionality

Characteristic	Specification
PCI Initiator (Master) Capability	Supported
PCI Target (Slave) Capability	Supported
Data Path	32 bits

Characteristic	Specification
Card Voltage/Type	5 V only; 32-bit 3U-size card
Parity Generation/Checking, Error Reporting	Supported
Target Decode Speed	Medium (one clock)
Target Fast-Back-to-Back Capability	Supported
Resource Locking	Supported as a master and slave
PCI Interrupts	Interrupts passed on INTA# signal
Base Address Registers	BAR 0 dedicated to local registers BAR 1–3 size configurable from 256 B to 4 GB
Expansion ROM	8 KB
PCI Master Performance (Ideal Maximum)	132 MB/s (16 Dwords maximum)
PCI Slave Performance (Ideal Maximum)	33 MB/s (to local registers)

## Environmental

Characteristic	Specification
Temperature	0° to 55° C operating; –40° to 85° C storage
Relative Humidity	0% to 95% noncondensing, operating; 0% to 95% noncondensing, storage
EMI	FCC Class A Verified

## Requirements

Characteristic	Specification
Memory Space	32 KB minimum, programmable



## Physical

Characteristic	Specification
Board Dimensions	160 mm by 100 mm (6.3 by 3.94 in.)
Connectors	Single fully implemented MXI-2 connector
Slot Requirements	Single CompactPCI/PXI Peripheral Slot
MTBF	290,596 hours
Weight	0.18 Kg (0.4 lb.) typical (no DRAM installed)

## Electrical

Source	Typical	Direct Current (Max)
+5 VDC	2.2 A	3.5 A

## Performance

MXI Transfer Rate	
Peak	33 MB/s
Sustained	23 MB/s

# VXI-MXI-2

---

This sections lists the specifications for the VXI-MXI-2 module. These specifications apply equally to the VXI-MXI-2/B unless otherwise noted.

## MXIbus Capability Descriptions

- Master-mode A32, A24, and A16 addressing
- Master-mode block transfers and synchronous block transfers
- Slave-mode A32, A24, and A16 addressing
- Slave-mode block transfers and synchronous block transfers
- Master-mode D32, D16, and D08 data sizes
- Slave-mode D32, D16, and D08 data sizes
- Optional MXIbus System Controller
- Can be a fair MXIbus requester
- Can lock the MXIbus for indivisible transfers
- Can terminate the MXIbus
- MXIbus master retry support
- MXIbus slave retry support
- Interrupt handler for levels 7 to 1
- Interrupt requester for levels 7 to 1
- MXIbus D32, D16, D08(O) interrupt handler
- MXIbus D32, D16, D08(O) interrupter
- Release on Acknowledge or Register Access interrupter
- MXIbus bus timer (programmable limit)
- Automatic MXIbus System Controller detection
- Automatic MXIbus termination detection

## VMEbus Capability Codes

Capability Code	Description
A32, A24, A16 (master)	VMEbus master A32, A24, and A16 addressing
A32, A24, A16 (slave)	VMEbus slave A32, A24, and A16 addressing
D32, D16, D08(EO) (master)	VMEbus master D32, D16, and D08 data sizes
D32, D16, D08(EO) (slave)	VMEbus slave D32, D16, and D08 data sizes
BLT, MBLT (master)	VMEbus master block and D64 transfers
BLT, MBLT (slave)	VMEbus slave block and D64 transfers
RMW (master)	VMEbus master read/modify/write transfers
RMW (slave)	VMEbus slave read/modify/write transfers
RETRY (master)	VMEbus master retry support
RETRY (slave)	VMEbus slave retry support
FSD	First slot detector
SCON	VMEbus System Controller
PRI, RRS	Prioritized or Round Robin Select arbiter
ROR, FAIR	Release on Request and FAIR bus requester
IH(7-1)	Interrupt handler for levels 7-1
I(7-1)	Interrupt requester for levels 7-1
D32, D16, D08(O) (Interrupt Handler)	VMEbus D32, D16, D08(O) interrupt handler
D32, D16, D08(O) (Interrupter)	VMEbus D32, D16, D08(O) interrupter
ROAK, RORA	Release on Acknowledge or Register Access interrupter
BTO(x)	VMEbus bus timer (programmable limit)

## Requirements

Characteristic	Specification
VXIbus Configuration Space	64 B
A24 or A32 Space	16 KB minimum (programmable)

## Environmental

Characteristic	Specification
Temperature	0° to 55° C operating; –40° to 85° C storage
Relative Humidity	0% to 95% noncondensing, operating; 0% to 95% noncondensing, storage
EMI	FCC Class A Verified

## Physical

C-Size VXI-MXI-2	
Characteristic	Specification
Board Dimensions	Fully enclosed, shielded VXI C-size board 233.35 by 340 mm (9.187 by 13.386 in.)
Connectors	Single fully implemented MXI-2 bus connector and three SMB connectors
Slot Requirements	Single VXI C-size slot
Compatibility	Fully compatible with VXI specification
VXI Keying Class	Class 1 TTL
MTBF	Contact factory
Weight	1.027 Kg (2.26 lb) typical (no DRAM installed)

<b>B-Size VXI-MXI-2/B</b>	
<b>Characteristic</b>	<b>Specification</b>
Board Dimensions	VXI B-size board 233.35 by 160 mm (9.187 by 6.2999 in.)
Connectors	Single fully implemented MXI-2 bus connector and three SMB connectors
Slot Requirements	Single VXI B-size slot
Compatibility	Fully compatible with VXI specification
VXI Keying Class	Class 1 TTL
MTBF	Contact factory
Weight	0.36 Kg (0.79 lb) typical (no DRAM installed)

## Electrical

<b>Source</b>	<b>DC Current Ratings</b>	
	<b>Typical</b>	<b>Maximum</b>
+5 VDC	2.5 A	3.5 A
-5.2 VDC	180 mA	225 mA
-2 VDC	80 mA	100 mA

## Performance

<b>VME Transfer Rate</b>	
Peak	33 MB/s
Sustained	23 MB/s

# VME-MXI-2

---

This section lists the specifications for the VME-MXI-2 module.

## MXIbus Capability Descriptions

- Master-mode A32, A24 and A16 addressing
- Master-mode block transfers and synchronous block transfers
- Slave-mode A32, A24, and A16 addressing
- Slave-mode block transfers and synchronous block transfers
- Master-mode D32, D16, and D08 data sizes
- Slave-mode D32, D16, and D08 data sizes
- Optional MXIbus System Controller
- Can be a fair MXIbus requester
- Can lock the MXIbus for indivisible transfers
- Can terminate the MXIbus
- MXIbus master retry support
- MXIbus slave retry support
- Interrupt handler for levels 7 to 1
- Interrupt requester for levels 7 to 1
- MXIbus D32, D16, D08(O) interrupt handler
- MXIbus D32, D16, D08(O) interrupter
- Release on Acknowledge or Register Access interrupter
- MXIbus bus timer (programmable limit)
- Automatic MXIbus System Controller detection
- Automatic MXIbus termination detection

## VMEbus Capability Codes

Capability Code	Description
A32, A24, A16 (master)	VMEbus master A32, A24, and A16 addressing
A32, A24, A16 (slave)	VMEbus slave A32, A24, and A16 addressing
D32, D16, D08(E0) (master)	VMEbus master D32, D16, and D08 data sizes
D32, D16, D08(E0) (slave)	VMEbus slave D32, D16, and D08 data sizes
BLT, MBLT (master)	VMEbus master block and D64 transfers
BLT, MBLT (slave)	VMEbus slave block and D64 transfers
RMW (master)	VMEbus master read/modify/write transfers
RMW (slave)	VMEbus slave read/modify/write transfers
RETRY (master)	VMEbus master retry support
RETRY (slave)	VMEbus slave retry support
FSD	First slot detector
SCON	VMEbus System Controller
PRI, RRS	Prioritized or Round Robin Select arbiter
ROR, FAIR	Release on Request and FAIR bus requester
IH(7-1)	Interrupt handler for levels 7-1
I(7-1)	Interrupt requester for levels 7-1
D32, D16, D08(O) (Interrupt Handler)	VMEbus D32, D16, D08(O) interrupt handler
D32, D16, D08(O) (Interrupter)	VMEbus D32, D16, D08(O) interrupter
ROAK, RORA	Release on Acknowledge or Register Access interrupter
BTO(x)	VMEbus bus timer (programmable limit)

## Requirements

Characteristic	Specification
A16 Space	64 B
A24 or A32 Space	16 KB minimum (programmable)

## Environmental

Characteristic	Specification
Temperature	0° to 55° C operating; –40° to 85° C storage
Relative Humidity	0% to 95% noncondensing, operating; 0% to 95% noncondensing, storage
EMI	FCC Class A Verified

## Physical

Characteristic	Specification
Board Dimensions	VMEbus double-height board 233.36 by 160 mm (9.187 by 6.2999 in.)
Connectors	Single fully implemented MXI-2 bus connector
Slot Requirements	Single VMEbus double-height slot
Compatibility	Fully compatible with VMEbus specification
MTBF	184,366 hours
Weight	0.33 Kg (0.73 lb) typical (no DRAM installed)



## Electrical

Source	DC Current Ratings	
	Typical	Maximum
+5 VDC	2.2 A	3.2 A

## Performance

VME Transfer Rate	
Peak	33 MB/s
Sustained	23 MB/s

# EEPROM Configuration

---

Appendix

**B**

This appendix describes how to control the operation of the PCI-MXI-2 or PXI-8320 onboard EEPROM and how to fix an invalid EEPROM setting.

The EEPROM stores default register values that are loaded at power-on. The EEPROM is divided into two halves so that you can modify one half, while the factory-configured half retains a back-up of the default user settings.

## Controlling the EEPROM Operation

---

Use switch 1 (FOV) of the four-position switch (at location U17 on the PCI-MXI-2, or at U6 on the PXI-8320) to control the operation of the EEPROM. Switch 1 determines whether the PCI-MXI-2 or PXI-8320 boots from the factory-configured half or the user-configurable half. In its default setting, the PCI-MXI-2 or PXI-8320 boots from the user-configurable half. This switch is useful in the event that the configuration becomes corrupted in such a way that the PCI-MXI-2 or PXI-8320 boots to an unusable state.

The TST switch (switch 2 of U17 or U6) lets you change the default factory configuration settings by permitting writes to the factory settings section of the EEPROM. This switch serves as a safety measure and is not needed under normal circumstances. When this switch is off (its default setting) the factory configuration of the EEPROM is protected so any writes to the factory area are ignored. The factory area is protected regardless of the setting of switch 1.

Figures B-1 and B-2 show the default settings for EEPROM operation.



**Caution:** *Do not alter the settings of switches 3 and 4. Leave these switches as shown unless specifically directed by National Instruments.*

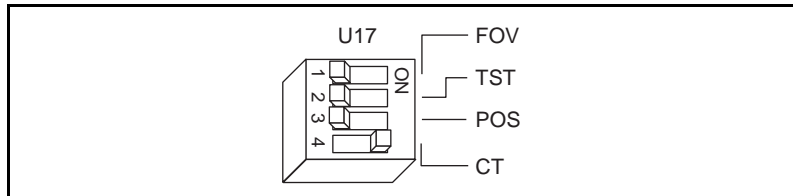

Figure B-1. Normal EEPROM Operation on the PCI-MXI-2

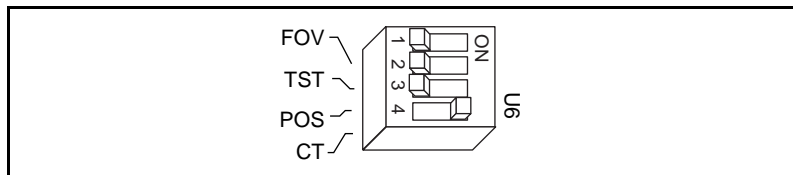

Figure B-2. Normal EEPROM Operation on the PXI-8320

## Fixing an Invalid EEPROM Configuration

Certain EEPROM configurations can cause your PCI-based or PXI/CompactPCI computer to lock up while in its boot process. Generally, only the size and location of the memory windows can cause the PCI-MXI-2 or PXI-8320 to lock up your system. For example, many PCI-based or PXI/CompactPCI computers will not boot if a board in the system requests more memory space than the computer can allocate. If you encounter this situation you should reduce the size of the PCI-MXI-2 or PXI-8320 user window.

If this situation occurs after changing the configuration, follow these steps to reconfigure the PCI-MXI-2 or PXI-8320.

1. Turn your computer or chassis off.



**Warning:** *To protect both yourself and the chassis from electrical hazards, leave the computer or chassis off while you change the settings on the PCI-MXI-2 or PXI-8320 module.*

2. Remove the PCI-MXI-2 or PXI-8320 from your PCI-based computer or PXI/CompactPCI chassis.
3. Change switch 1 (FOV) on U17 or U6 to the ON position as shown in Figures B-3 or B-4 to restore the factory configuration.

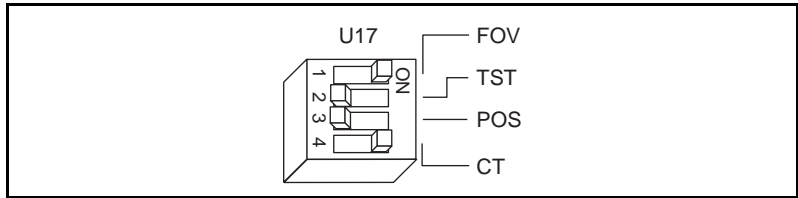

**Figure B-3.** Restoring the Factory Configuration on the PCI-MXI-2

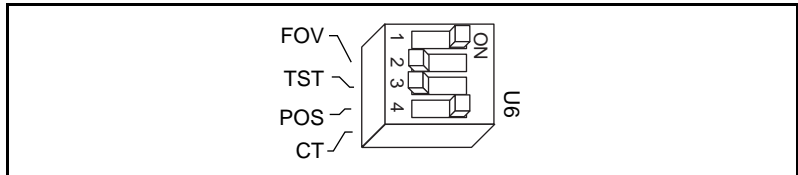

**Figure B-4.** Restoring the Factory Configuration on the PXI-8320



**Note:**

*If you have to remove the PCI-MXI-2 or PXI-8320 module to access switch 1, follow the installation instructions in Chapter 2, PCI-MXI-2 Configuration and Installation, to re-install the PCI-MXI-2 module or Chapter 3, PXI-8320 Configuration and Installation, to re-install the PXI-8320 module.*

4. Replace the PCI-MXI-2 or PXI-8320.
5. Turn on the PCI-based computer or PXI/CompactPCI chassis. The computer should boot this time because the factory-default configuration is being used to initialize the module.
6. Run the configuration utility that came with your National Instruments software to re-adjust the PCI-MXI-2 or PXI-8320 configuration.
7. After saving the configuration, shut down the operating system and turn off the computer or chassis.
8. Remove the PCI-MXI-2 or PXI-8320.
9. Change switch 1 (FOV) to the OFF position.
10. Replace the PCI-MXI-2 or PXI-8320.
11. Turn on the computer or chassis. If it does not boot with this configuration, repeat these steps, modifying your configuration until the computer or chassis boots successfully.

# National Instruments Software Choices

---

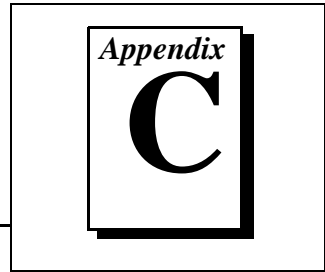

This section discusses the National Instruments software available for your MXI-2 kit.

If you choose to program your VXI system using a standard language such as C, C++, BASIC, ADA, or ATLAS, you should realize that standard programming languages do not come with built-in VXI capability. Rather, VXI capability is added through a VXI bus interface software library. This software component is very important, because it affects the choice of VXI computer hardware, operating system, programming language, and ADE or application software package. Software is a major thrust for National Instruments, relating to our involvement with both the VXI Consortium and the *VXIplug&play* Systems Alliance.

## NI-VXI/VISA

---

If you ordered your MXI-2 hardware as part of a kit such as the VXI-PCI8000, you also received the NI-VXI/VISA bus interface software. This software consists of VXI-specific software (NI-VXI), as well as interface-independent software (NI-VISA) for certain platforms addressed by *VXIplug&play* standards. NI-VXI/VISA features integrated capability for single- and multiple-mainframe systems, software compatibility across all VXI controller platforms, and compatibility with the LabVIEW and LabWindows®/CVI application development environments (ADEs).

NI-VXI/VISA is a comprehensive software package for configuring, programming, and troubleshooting a VXI system. It features a complete set of high-performance routines for programming VXI using industry-standard programming languages, and intuitive tools for interacting with and troubleshooting VXI systems. The NI-VXI/VISA bus interface software makes your kit completely compliant with *VXIplug&play* Systems Alliance specifications. You can run all of the latest *VXIplug&play* software, including executable soft front panels, with which you can operate the instrument immediately.

The bulk of this manual described how to use hardware jumpers and switches to configure your MXI-2 boards. However, you can handle a substantial portion of your configuration task through the interactive configuration utilities that come with NI-VXI/VISA. This software also includes a Resource Manager, an interactive control program, a debugging utility, and online help.

Refer to your getting started manual for more information about the NI-VXI/VISA software.

## Application Development Environments

---

You may also want to consider using the National Instruments LabVIEW and LabWindows/CVI application programs and instrument drivers to ease your programming task. These standardized programs match the modular virtual instrument capability of VXI and can reduce your VXI/VMEbus software development time. These programs are fully VXI *plug&play* compliant and feature extensive libraries of VXI instrument drivers written to take full advantage of direct VXI control. LabVIEW and LabWindows/CVI include all the tools needed for instrument control, data acquisition, analysis, and presentation.

LabVIEW is a complete programming environment that departs from the sequential nature of traditional programming languages and features a graphical programming environment.

LabWindows/CVI is an interactive C development environment for building test and measurement and instrument control systems. It includes interactive code-generation tools and a graphical editor for building custom user interfaces.

If you want to use either of these application programs, install them when prompted during the NI-VXI/VISA software installation. You automatically receive the necessary VXI libraries to support your PCI-based MXI-2 products. You also get hundreds of complete instrument drivers, which are modular, source-code programs that handle the communication with your instrument to speed your application development.

# Customer Communication

---

Appendix

D

For your convenience, this appendix contains forms to help you gather the information necessary to help us solve your technical problems and a form you can use to comment on the product documentation. When you contact us, we need the information on the Technical Support Form and the configuration form, if your manual contains one, about your system configuration to answer your questions as quickly as possible.

National Instruments has technical assistance through electronic, fax, and telephone systems to quickly provide the information you need. Our electronic services include a bulletin board service, an FTP site, a FaxBack system, and e-mail support. If you have a hardware or software problem, first try the electronic support systems. If the information available on these systems does not answer your questions, we offer fax and telephone support through our technical support centers, which are staffed by applications engineers.

## Electronic Services



### Bulletin Board Support

National Instruments has BBS and FTP sites dedicated for 24-hour support with a collection of files and documents to answer most common customer questions. From these sites, you can also download the latest instrument drivers, updates, and example programs. For recorded instructions on how to use the bulletin board and FTP services and for BBS automated information, call (512) 795-6990. You can access these services at:

United States: (512) 794-5422

Up to 14,400 baud, 8 data bits, 1 stop bit, no parity

United Kingdom: 01635 551422

Up to 9,600 baud, 8 data bits, 1 stop bit, no parity

France: 01 48 65 15 59

Up to 9,600 baud, 8 data bits, 1 stop bit, no parity



### FTP Support

To access our FTP site, log on to our Internet host, `ftp.natinst.com`, as anonymous and use your Internet address, such as `joesmith@anywhere.com`, as your password. The support files and documents are located in the `/support` directories.



## Fax-On-Demand Support

FaxBack is a 24-hour information retrieval system containing a library of documents on a wide range of technical information. You can access FaxBack from a touch-tone telephone at (512) 418-1111.



## E-Mail Support (currently U.S. only)

You can submit technical support questions to the applications engineering team through e-mail at the Internet address listed below. Remember to include your name, address, and phone number so we can contact you with solutions and suggestions.

[support@natinst.com](mailto:support@natinst.com)

## Fax and Telephone Support

National Instruments has branch offices all over the world. Use the list below to find the technical support number for your country. If there is no National Instruments office in your country, contact the source from which you purchased your software to obtain support.

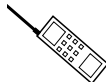

### Telephone



### Fax

Australia	03 9879 5166	03 9879 6277
Austria	0662 45 79 90 0	0662 45 79 90 19
Belgium	02 757 00 20	02 757 03 11
Canada (Ontario)	905 785 0085	905 785 0086
Canada (Quebec)	514 694 8521	514 694 4399
Denmark	45 76 26 00	45 76 26 02
Finland	09 725 725 11	09 725 725 55
France	01 48 14 24 24	01 48 14 24 14
Germany	089 741 31 30	089 714 60 35
Hong Kong	2645 3186	2686 8505
Israel	03 5734815	03 5734816
Italy	02 413091	02 41309215
Japan	03 5472 2970	03 5472 2977
Korea	02 596 7456	02 596 7455
Mexico	5 520 2635	5 520 3282
Netherlands	0348 433466	0348 430673
Norway	32 84 84 00	32 84 86 00
Singapore	2265886	2265887
Spain	91 640 0085	91 640 0533
Sweden	08 730 49 70	08 730 43 70
Switzerland	056 200 51 51	056 200 51 55
Taiwan	02 377 1200	02 737 4644
U.K.	01635 523545	01635 523154



# Technical Support Form

Photocopy this form and update it each time you make changes to your software or hardware, and use the completed copy of this form as a reference for your current configuration. Completing this form accurately before contacting National Instruments for technical support helps our applications engineers answer your questions more efficiently.

If you are using any National Instruments hardware or software products related to this problem, include the configuration forms from their user manuals. Include additional pages if necessary.

Name \_\_\_\_\_

Company \_\_\_\_\_

Address \_\_\_\_\_

\_\_\_\_\_

Fax (\_\_\_\_) \_\_\_\_\_ Phone (\_\_\_\_) \_\_\_\_\_

Computer brand \_\_\_\_\_ Model \_\_\_\_\_ Processor \_\_\_\_\_

Operating system (include version number) \_\_\_\_\_

Clock speed \_\_\_\_\_ MHz RAM \_\_\_\_\_ MB Display adapter \_\_\_\_\_

Mouse \_\_\_yes \_\_\_no Other adapters installed \_\_\_\_\_

Hard disk capacity \_\_\_\_\_ MB Brand \_\_\_\_\_

Instruments used \_\_\_\_\_

\_\_\_\_\_

National Instruments hardware product model \_\_\_\_\_ Revision \_\_\_\_\_

Configuration \_\_\_\_\_

National Instruments software product \_\_\_\_\_ Version \_\_\_\_\_

Configuration \_\_\_\_\_

The problem is: \_\_\_\_\_

\_\_\_\_\_

\_\_\_\_\_

\_\_\_\_\_

List any error messages: \_\_\_\_\_

\_\_\_\_\_

\_\_\_\_\_

The following steps reproduce the problem: \_\_\_\_\_

\_\_\_\_\_

\_\_\_\_\_

\_\_\_\_\_

\_\_\_\_\_

\_\_\_\_\_

# Hardware Configuration Form

Record the settings and revisions of your hardware on the line to the right of each item. Complete a new copy of this form each time you revise your hardware configuration, and use this form as a reference for your current configuration. Completing this form accurately before contacting National Instruments for technical support helps our applications engineers answer your questions more efficiently. For a more complete configuration form that includes software options, refer to the *Hardware and Software Configuration Form* in your getting started manual.

## PCI-MXI-2

Hardware Revision Number \_\_\_\_\_

Switch U17 Settings \_\_\_\_\_

DRAM SIMM Installed \_\_\_\_\_

## PXI-8320

Hardware Revision Number \_\_\_\_\_

Using PXI or Compact/PCI? \_\_\_\_\_

Slot Location \_\_\_\_\_

Switch U6 Settings \_\_\_\_\_

DRAM SO-DIMM Installed \_\_\_\_\_

## C-Size VXI-MXI-2 Hardware Configuration

Hardware Revision Number \_\_\_\_\_

Slot Location \_\_\_\_\_

VXIBus Logical Address Switch Setting (U43) \_\_\_\_\_

VXIBus Slot 0/Non-Slot 0 (W2) \_\_\_\_\_

VXIBus CLK10 Routing (W3) \_\_\_\_\_

SMB CLK10 (S3, S4, S5) \_\_\_\_\_

Receiving or Driving MXIBus CLK10 (S7) \_\_\_\_\_

Trigger Input Termination (S2) \_\_\_\_\_

MXIBus Termination (U35 switches 1 and 2) \_\_\_\_\_

EEPROM Operation (U35 switches 3 and 4) \_\_\_\_\_

Onboard DRAM SIMM Size (S6) \_\_\_\_\_

DRAM SIMMs Installed \_\_\_\_\_

VXIBus Local Bus (S8, S9) \_\_\_\_\_

## **B-Size VXI-MXI-2/B Hardware Configuration**

Hardware Revision Number \_\_\_\_\_

Slot Location \_\_\_\_\_

VXIbus Logical Address Switch Setting (U20) \_\_\_\_\_

VXIbus Slot 0/Non-Slot 0 (W3) \_\_\_\_\_

VXIbus CLK10 Routing (W1) \_\_\_\_\_

SMB CLK10 (S7, S6, S3) \_\_\_\_\_

Receiving or Driving MXIbus CLK10 (S1) \_\_\_\_\_

Trigger Input Termination (S5) \_\_\_\_\_

MXIbus Termination (U21 switches 3 and 4) \_\_\_\_\_

EEPROM Operation (U21 switches 1 and 2) \_\_\_\_\_

Onboard DRAM SIMM Size (S2) \_\_\_\_\_

DRAM SIMMs Installed \_\_\_\_\_

VXIbus Local Bus (W2) \_\_\_\_\_

## **VME-MXI-2 Hardware Configuration**

Hardware Revision Number \_\_\_\_\_

Slot Location \_\_\_\_\_

VMEbus A16 Base Address (U20) \_\_\_\_\_

MXIbus Termination (U21 switches 3 and 4) \_\_\_\_\_

EEPROM Operation (U21 switches 1 and 2) \_\_\_\_\_

Onboard DRAM SIMM Size (S2) \_\_\_\_\_

DRAM SIMMs Installed \_\_\_\_\_

VME-MXI-2 Intermodule Signaling (W2) \_\_\_\_\_

## **Other Products**

Computer Make and Model \_\_\_\_\_

Mainframe Make and Model \_\_\_\_\_

Microprocessor \_\_\_\_\_

Clock Frequency \_\_\_\_\_

Type of Video Board Installed \_\_\_\_\_

Operating System \_\_\_\_\_

Operating System Version \_\_\_\_\_

Operating System Mode \_\_\_\_\_



# Documentation Comment Form

National Instruments encourages you to comment on the documentation supplied with our products. This information helps us provide quality products to meet your needs.

**Title:** *MXI-2 Configuration Reference Manual*

**Edition Date:** September 1997

**Part Number:** 321713A-01

Please comment on the completeness, clarity, and organization of the manual.

---

---

---

---

---

---

---

---

If you find errors in the manual, please record the page numbers and describe the errors.

---

---

---

---

---

---

---

---

Thank you for your help.

Name \_\_\_\_\_

Title \_\_\_\_\_

Company \_\_\_\_\_

Address \_\_\_\_\_

---

Phone (\_\_\_\_) \_\_\_\_\_ Fax (\_\_\_\_) \_\_\_\_\_

**Mail to:** Technical Publications  
National Instruments Corporation  
6504 Bridge Point Parkway  
Austin, TX 78730-5039

**Fax to:** Technical Publications  
National Instruments Corporation  
(512) 794-5678

<b>Prefix</b>	<b>Meaning</b>	<b>Value</b>
n-	nano-	$10^{-9}$
$\mu$ -	micro-	$10^{-6}$
m-	milli-	$10^{-3}$
K-	kilo-	$10^3$
M-	mega-	$10^6$
G-	giga-	$10^9$

## Symbols

°	degrees
$\Omega$	ohms
%	percent

## A

A amperes

A16 space VXIbus address space equivalent to the VME 64 KB short address space. In VXI, the upper 16 KB of A16 space is allocated for use by VXI devices configuration registers. This 16 KB region is referred to as VXI configuration space.

A24 space VXIbus address space equivalent to the VME 16 MB *standard* address space.

A32 space	VXIbus address space equivalent to the VME 4 GB <i>extended</i> address space.
ACFAIL	A VMEbus backplane signal that is asserted when a power failure has occurred (either AC line source or power supply malfunction), or if it is necessary to disable the power supply (such as for a high temperature condition).
address	Character code that identifies a specific location (or series of locations) in memory.
address modifier	One of six signals in the VMEbus specification used by VMEbus masters to indicate the address space in which a data transfer is to take place.
address space	A set of $2^n$ memory locations differentiated from other such sets in VXI/VMEbus systems by six addressing lines known as address modifiers. $n$ is the number of address lines required to uniquely specify a byte location in a given space. Valid numbers for $n$ are 16, 24, and 32. In VME/VXI, because there are six address modifiers, there are 64 possible address spaces.
address window	A portion of address space that can be accessed from the application program.
ANSI	American National Standards Institute
arbitration	A process in which a potential bus master gains control over a particular bus.
asynchronous	Not synchronized; not controlled by time signals.
<b>B</b>	
B	bytes
backplane	An assembly, typically a printed circuit board, with 96-pin connectors and signal paths that bus the connector pins. A C-size VXIbus system has two sets of bused connectors called J1 and J2. A D-size VXIbus system has three sets of bused connectors called J1, J2, and J3.
BERR*	Bus error signal
binary	A numbering system with a base of 2.

BIOS	Basic Input/Output System. BIOS functions are the fundamental level of any PC or compatible computer. BIOS functions embody the basic operations needed for successful use of the computer's hardware resources.
block-mode transfer	An uninterrupted transfer of data elements in which the master sources only the first address at the beginning of the cycle. The slave is then responsible for incrementing the address on subsequent transfers so that the next element is transferred to or from the proper storage location. In VME, the data transfer may have no more than 256 elements; MXI does not have this restriction.
BTO unit	Bus Timeout unit; a functional module that times the duration of each data transfer and terminates the cycle if the duration is excessive. Without the termination capability of this module, a bus master attempt to access a nonexistent slave could result in an indefinitely long wait for a slave response.
bus master	A device that is capable of requesting the Data Transfer Bus (DTB) for the purpose of accessing a slave device.
<b>C</b>	
C	Celsius
CLK10	A 10 MHz, $\pm 100$ ppm, individually buffered (to each module slot), differential ECL system clock that is sourced from Slot 0 of a VXIBus mainframe and distributed to Slots 1 through 12 on P2. It is distributed to each slot as a single-source, single-destination signal with a matched delay of under 8 ns.
CMOS	Complementary Metal Oxide Semiconductor; a process used in making chips.
Commander	A message-based device which is also a bus master and can control one or more Servants.
CompactPCI	An adaptation of the PCI specification for industrial and/or embedded applications that require a more robust mechanical form factor than desktop PCI. CompactPCI provides a standard form factor for those applications requiring the high performance of PCI as well as the small size and ruggedness of a rack-mount system.



configuration registers A set of registers through which the system can identify a module device type, model, manufacturer, address space, and memory requirements. To support automatic system and memory configuration, the VXIbus specification requires that all VXIbus devices have a set of such registers.

## D

daisy-chain A method of propagating signals along a bus, in which the devices are prioritized on the basis of their position on the bus.

Data Transfer Bus DTB; one of four buses on the VMEbus backplane. The DTB is used by a bus master to transfer binary data between itself and a slave device.

DIP Dual Inline Package

DMA Direct Memory Access; a method by which data is transferred between devices and internal memory without intervention of the central processing unit.

DRAM Dynamic RAM

driver window A region of PCI address space that is decoded by the PCI-MXI-2 or PXI-8320 for use by the NI-VXI software.

DTACK\* Data Acknowledge signal

DTB See *Data Transfer Bus*.

dynamic configuration A method of automatically assigning logical addresses to VXIbus devices at system startup or other configuration times.

dynamically configured device A device that has its logical address assigned by the Resource Manager. A VXI device initially responds at logical address 255 when its MODID line is asserted. A MXIbus device responds at logical address 255 during a priority select cycle. The Resource Manager subsequently assigns it a new logical address, which the device responds to until powered down.

## E

ECL Emitter-Coupled Logic

EEPROM	Electrically Erasable Programmable Read Only Memory
EMC	Electromechanical Compliance
EMI	Electromagnetic Interference
expansion ROM	An onboard EEPROM that may contain device-specific initialization and system boot functionality.
external controller	In this configuration, a plug-in interface board in a computer is connected to the VXI mainframe via one or more VXIbus extended controllers. The computer then exerts overall control over VXIbus system operations.

## F

fair requester	A MXIbus master that does not arbitrate for the MXIbus after releasing it until it detects the bus request signal inactive. This ensures that all requesting devices are granted use of the bus.
----------------	--

## H

hex	Hexadecimal; the numbering system with base 16, using the digits 0 to 9 and letters A to F.
Hz	hertz; cycles per second.

## I

IC	Integrated Circuit
IEEE	Institute of Electrical and Electronics Engineers
in.	inches
I/O	input/output; the techniques, media, and devices used to achieve communication between machines and users.
interrupt	A means for a device to request service from another device.

interrupt handler	A VMEbus functional module that detects interrupt requests generated by Interrupters and responds to those requests by requesting status and identify information.
interrupt level	The relative priority at which a device can interrupt.
IRQ*	Interrupt signal
<b>K</b>	
KB	Kilobytes of memory
<b>L</b>	
LED	Light Emitting Diode
logical address	An 8-bit number that uniquely identifies each VXIbus device in a system. It defines the A16 register address of a device, and indicates Commander and Servant relationships.
<b>M</b>	
m	meters
master	A functional part of a MXI/VME/VXIbus device that initiates data transfers on the backplane. A transfer can be either a read or a write.
master-mode operation	A device is in master mode if it is performing a bus cycle which it initiated.
MB	Megabytes of memory
MBLT	Eight-byte block transfers in which both the Address bus and the Data bus are used to transfer data.
message-based device	An intelligent device that implements the defined VXIbus registers and communication protocols. These devices are able to use Word Serial Protocol to communicate with one another through communication registers.

MITE	A National Instruments custom ASIC, a sophisticated dual-channel DMA controller that incorporates the Synchronous MXI and VME64 protocols to achieve high-performance block transfer rates.
MODID	Module Identification lines
MTBF	Mean Time Between Failure
MXI-2	The second generation of the National Instruments MXIbus product line. MXI-2 expands the number of signals on a standard MXIbus cable by including VXI triggers, all VXI interrupts, CLK10, SYSFAIL*, SYSRESET*, and ACFAIL*. MXI-2 also defines new higher-performance data protocols.
MXIbus	Multisystem eXtension Interface Bus; a high-performance communication link that interconnects devices using round, flexible cables.
MXIbus System Controller	A functional module that has arbiter, daisy-chain driver, and MXIbus cycle timeout responsibility. Always the first device in the MXIbus daisy-chain.

## N

NI-VXI	The National Instruments bus interface software for VXI/VMEbus systems.
NI-VISA	The National Instruments implementation of the VISA standard; an interface-independent software that provides a unified programming interface for VXI, GPIB, and serial instruments.
Non-Slot 0 device	A device configured for installation in any slot in a VXIbus mainframe other than Slot 0. Installing such a device into Slot 0 can damage the device, the VXIbus backplane, or both.

## O

Onboard RAM	The optional RAM installed into the SIMM slots of the MXI-2 board.
-------------	--

## P

PCI	Peripheral Component Interconnect. The PCI bus is a high-performance 32-bit or 64-bit bus with multiplexed address and data lines.
propagation	The transmission of a signal through a computer system.
PXI	PCI eXtensions for Instrumentation; an open implementation of CompactPCI that adds electrical features that meet the high-performance requirements of instrumentation applications by providing triggering, local buses, and system clock capabilities. PXI also offers two-way interoperability with CompactPCI products.

## R

register-based device	A Servant-only device that supports VXIbus configuration registers. Register-based devices are typically controlled by message-based devices via device-dependent register reads and writes.
retry	An acknowledge by a destination that signifies that the cycle did not complete and should be repeated.
Resource Manager	A message-based Commander located at Logical Address 0, which provides configuration management services such as address map configuration, Commander and Servant mappings, and self-test and diagnostic management.

## S

s	seconds
Servant	A device controlled by a Commander; there are message-based and register-based Servants.
Shared Memory Protocol	A communication protocol that uses a block of memory accessible to both a client and a server. The memory block operates as a message buffer for communications.
SIMM	Single In-line Memory Module

slave	A functional part of a MXI/VME/VXIbus device that detects data transfer cycles initiated by a VMEbus master and responds to the transfers when the address specifies one of the device's registers.
slave-mode operation	A device is in slave mode if it is responding to a bus cycle.
Slot 0 device	A device configured for installation in Slot 0 of a VXIbus mainframe. This device is unique in the VXIbus system in that it performs the VMEbus System Controller functions, including clock sourcing and arbitration for data transfers across the backplane. Installing such a device into any other slot can damage the device, the VXIbus backplane, or both.
SO-DIMM	Small Outline Dual Inline Memory Module; used in the PXI-8320.
statically configured device	A device whose logical address cannot be set through software; that is, it is not dynamically configurable.
SYSFAIL	A VMEbus signal that a device uses to indicate an internal failure. A failed device asserts this line. In VXI, a device that fails also clears its PASSEd bit in its Status register.
SYSRESET	A VMEbus signal that a device uses to indicate a system reset or power-up condition.
System RAM	RAM installed on your personal computer and used by the operating system, as contrasted with onboard RAM, which is installed on the MXI-2 board.

## T

trigger	Either TTL or ECL lines used for intermodule timing.
TTL	Transistor-Transistor Logic

## U

user window	A region of PCI address space reserved by the PCI-MXI-2 or PXI-8320 for use via the NI-VXI low-level function calls. <code>MapVXIAddress()</code> uses this address space to allocate regions for use by the <code>VXIpeek()</code> and <code>VXIpoke()</code> macros.
-------------	--

## **V**

V	volts
VDC	volts direct current
VME	Versa Module Eurocard or IEEE 1014
VMEbus System Controller	A device configured for installation in Slot 0 of a VXIbus mainframe or Slot 1 of a VMEbus chassis. This device is unique in the VMEbus system in that it performs the VMEbus System Controller functions, including clock sourcing and arbitration for data transfers across the backplane. Installing such a device into any other slot can damage the device, the VMEbus/VXIbus backplane, or both.
VXIbus	VMEbus eXtensions for Instrumentation

## **W**

Word Serial Protocol	The simplest required communication protocol supported by message-based devices in a VXIbus system. It utilizes the A16 communication registers to transfer data using a simple polling handshake method.
----------------------	---

## A

A16 base address, VMEbus, 6-3 to 6-4

## C

CLK10 routing, VXIbus

VXI-MXI-2 module, 4-6 to 4-10

CLK10 generated from MXIbus  
(figure), 4-7

CLK10 generated from onboard  
oscillator (figure), 4-7

CLK10 generated from SMB  
(figure), 4-7

drive inverted external CLK SMB  
(figure), 4-9

drive non-inverted external CLK SMB  
(figure), 4-9

receive external CLK SMB  
(figure), 4-9

receive external CLK SMB with 50  
ohm termination (figure), 4-9

receiving or driving MXIbus CLK10  
(figure), 4-10

VXI-MXI-2/B module, 5-6 to 5-9

CLK10 generated from MXIbus  
(figure), 5-6

CLK10 generated from onboard  
oscillator (figure), 5-6

CLK10 generated from SMB  
(figure), 5-6

drive inverted external CLK SMB  
(figure), 5-8

drive non-inverted external CLK SMB  
(figure), 5-8

receive external CLK SMB  
(figure), 5-8

receive external CLK SMB with 50  
ohm termination (figure), 5-8

receiving or driving MXIbus CLK10  
(figure), 5-9

configuration

PCI-MXI-2 module, 2-1 to 2-3

configuration EEPROM, 2-3

onboard DRAM, 2-3

parts locator diagram, 2-2

PXI-8320 module, 3-1 to 3-3

configuration EEPROM, 3-2

onboard DRAM, 3-2 to 3-3

parts locator diagram, 3-2

VME-MXI-2 module, 6-1 to 6-10

configuration EEPROM, 6-5 to 6-7

front panel features, 6-3

MXIbus termination, 6-4 to 6-5

onboard DRAM, 6-7 to 6-9

DRAM configurations (table),  
6-8 to 6-9

SIMM size configuration  
(figure), 6-8

parts locator diagram, 6-2

VMEbus A16 base address, 6-3 to 6-4

VME-MXI-2 intermodule signaling,  
6-9 to 6-10

VXI-MXI-2 module, 4-1 to 4-17

configuration EEPROM, 4-12 to 4-14

front panel features, 4-3

MXIbus termination, 4-11 to 4-12

onboard DRAM, 4-14 to 4-16

removing metal enclosure, 4-3



- right-side cover (figure), 4-2
- trigger input termination,
  - 4-10 to 4-11
- VXibus CLK10 routing, 4-6 to 4-10
- VXibus local bus, 4-16 to 4-17
- VXibus logical address, 4-3 to 4-5
- VXibus Slot 0/non-Slot 0, 3-5 to 3-6
- VXI-MXI-2/B module, 5-1 to 5-15
  - configuration EEPROM,
    - 5-11 to 5-12
  - front panel features, 5-3
  - MXibus termination, 5-9 to 5-10
  - onboard DRAM, 5-12 to 5-14
  - parts locator diagram, 5-2
  - trigger input termination, 5-9
  - VXibus CLK10 routing, 5-6 to 5-9
  - VXibus local bus, 5-14 to 5-15
  - VXibus logical address, 5-3 to 5-4
  - VXibus Slot 0/Non-Slot 0, 5-4 to 5-5
- configuration EEPROM, B-1 to B-3
  - controlling EEPROM operation,
    - B-1 to B-2
  - fixing invalid EEPROM configuration,
    - B-2 to B-3
  - PCI-MXI-2 module, 2-3
  - PXI-8320 module, 3-2
  - VME-MXI-2 module, 6-5 to 6-7
  - VXI-MXI-2 module, 4-12 to 4-14
  - VXI-MXI-2/B module, 5-11 to 5-12
- customer communication, *xii*, D-1 to D-2

## D

- documentation
  - conventions used in manual, *x*
  - how to use documentation set, *x-xi*
  - how to use this manual (figure), 1-1
  - organization of manual, *ix-x*
  - related documentation, *xi-xii*

- DRAM configuration. *See* onboard DRAM configuration.
- D-size VXI mainframes, with P3 connector (note), 1-3

## E

- EEPROM. *See* configuration EEPROM.
- electrical specifications
  - PCI-MXI-2, A-3
  - PXI-8320, A-6
  - VME-MXI-2 module, A-14
  - VXI-MXI-2 module, A-10
- electronic support services, D-1 to D-2
- e-mail support, D-2
- environmental specifications
  - PCI-MXI-2, A-2
  - PXI-8320, A-5
  - VME-MXI-2 module, A-13
  - VXI-MXI-2 module, A-9

## F

- fax and telephone support, D-2
- Fax-on-Demand support, D-2
- FTP support, D-1

## I

- installation
  - PCI-MXI-2 module, 2-4 to 2-5
  - PXI-8320 module, 3-3 to 3-4
  - VME-MXI-2 module, 6-10 to 6-11
  - VXI-MXI-2 module, 4-18
  - VXI-MXI-2/B module, 5-15 to 5-16

**L**

- LabVIEW software, C-2
- LabWindows/CVI software, C-2
- local bus, VXIbus
  - VXI-MXI-2 module, 4-16 to 4-17
  - VXI-MXI-2/B, 5-14 to 5-15
- logical address
  - configuration
    - VXI-MXI-2 module, 4-3 to 4-5
    - VXI-MXI-2/B module, 5-3 to 5-4
  - definition, 4-3, 5-3

**M**

- manual. *See* documentation.
- memory configuration. *See* onboard DRAM configuration.
- memory requirement specifications
  - PCI-MXI-2, A-3
  - PXI-8320, A-5
  - VME-MXI-2, A-13
  - VXI-MXI-2, A-9
- MITE custom ASIC, 1-4 to 1-5
- MXI-2 description, 1-2
- MXI-2 interface kit
  - MXI-2 description, 1-2
  - overview, 1-2 to 1-3
- MXIbus cable connections
  - VME-MXI-2 module, 6-11 to 6-12
  - VXI-MXI-2 module, 4-19 to 4-20
  - VXI-MXI-2/B module, 5-16 to 5-17
- MXIbus capability descriptions
  - PCI-MXI-2 module, A-1
  - VME-MXI-2 module, A-11
  - VXI-MXI-2 module, A-7
- MXIbus termination
  - VME-MXI-2 module, 6-4 to 6-5
  - VXI-MXI-2 module, 4-11 to 4-12
  - VXI-MXI-2/B module, 5-9 to 5-10

**N**

- NI-VXI/VISA software, C-1 to C-2

**O**

- onboard DRAM configuration
  - PCI-MXI-2 module, 2-3
  - PXI-8320 module, 3-2 to 3-3
  - VME-MXI-2 module, 6-7 to 6-9
    - DRAM configurations (table), 6-8 to 6-9
    - SIMM size configuration (figure), 6-8
  - VXI-MXI-2 module, 4-14 to 4-16
    - DRAM configurations (table), 4-15 to 4-16
    - SIMM size configuration (figure), 4-15
  - VXI-MXI-2/B module, 5-12 to 5-14
    - DRAM configurations (table), 5-13 to 5-14
    - SIMM size configuration (figure), 5-13

**P**

- P3 connector on D-size VXI mainframes (note), 1-3
- PCI-MXI-2 module
  - configuration, 2-1 to 2-3
    - configuration EEPROM, 2-3
    - onboard DRAM, 2-3
    - parts locator diagram, 2-2
  - hardware description, 1-3 to 1-5
  - installation, 2-4 to 2-5
  - specifications
    - electrical, A-3
    - environmental, A-2
    - MXIbus capability descriptions, A-1
    - PCI functionality, A-2

- performance, A-3
- physical, A-3
- requirements, A-3
- performance specifications
  - PCI-MXI-2 module, A-3
  - PXI-8320 module, A-6
  - VME-MXI-2 module, A-14
  - VXI-MXI-2 module, A-10
- physical specifications
  - PCI-MXI-2, A-3
  - PXI-8320, A-6
  - VME-MXI-2 module, A-13
  - VXI-MXI-2 module, A-9 to A-10
- PXI-8320 module
  - configuration, 3-1 to 3-3
    - configuration EEPROM, 3-2
    - onboard DRAM, 3-2 to 3-3
    - parts locator diagram, 3-2
  - installation, 3-3 to 3-4
  - specifications
    - electrical, A-6
    - environmental, A-5
    - MXIbus capability descriptions, A-4
    - PCI functionality, A-4 to A-5
    - performance, A-6
    - physical, A-6
    - requirements, A-5

## R

RAM. *See* onboard DRAM configuration.

## S

- Slot 0/non-Slot 0 configuration
  - VXI-MXI-2 module, 3-5 to 3-6
  - VXI-MXI-2/B module, 5-4 to 5-5

- software
  - application development environments, C-2
  - NI-VXI/VISA software, C-1 to C-2
- specifications
  - PCI-MXI-2
    - electrical, A-3
    - environmental, A-2
    - MXIbus capability descriptions, A-1
    - PCI functionality, A-2
    - performance, A-3
    - physical, A-3
    - requirements, A-3
  - PXI-8320
    - electrical, A-6
    - environmental, A-5
    - MXIbus capability descriptions, A-4
    - PCI functionality, A-4 to A-5
    - performance, A-6
    - physical, A-6
    - requirements, A-5
  - VME-MXI-2
    - electrical, A-14
    - environmental, A-13
    - MXIbus capability descriptions, A-11
    - performance, A-14
    - physical, A-13
    - requirements, A-13
    - VMEbus capability codes, A-12
  - VXI-MXI-2
    - electrical, A-10
    - environmental, A-9
    - performance, A-10
    - physical, A-9 to A-10
    - requirements, A-9
    - VMEbus capability codes, A-8

**T**

- technical support, D-1 to D-2
- telephone and fax support, D-2
- trigger input termination
  - VXI-MXI-2 module, 4-10 to 4-11
  - VXI-MXI-2/B module, 5-9

**V**

- VMEbus capability codes
  - VME-MXI-2 module, A-12
  - VXI-MXI-2 module, A-8
- VME-MXI-2 module
  - configuration, 6-1 to 6-10
    - configuration EEPROM, 6-5 to 6-7
    - front panel features, 6-3
    - MXIbus termination, 6-4 to 6-5
    - onboard DRAM, 6-7 to 6-9
      - DRAM configurations (table), 6-8 to 6-9
      - SIMM size configuration (figure), 6-8
    - parts locator diagram, 6-2
    - VMEbus A16 base address, 6-3 to 6-4
    - VME-MXI-2 intermodule signaling, 6-9 to 6-10
  - connecting MXIbus cable, 6-11 to 6-12
  - installation, 6-10 to 6-11
  - specifications
    - electrical, A-14
    - environmental, A-13
    - MXIbus capability descriptions, A-11
    - performance, A-14
    - physical, A-13
    - requirements, A-13
    - VMEbus capability codes, A-12
- VXIbus CLK10 routing
  - VXI-MXI-2 module, 4-6 to 4-10
    - CLK10 generated from MXIbus (figure), 4-7
    - CLK10 generated from onboard oscillator (figure), 4-7
    - CLK10 generated from SMB (figure), 4-7
    - drive inverted external CLK SMB (figure), 4-9
    - drive non-inverted external CLK SMB (figure), 4-9
    - receive external CLK SMB (figure), 4-9
    - receive external CLK SMB with 50 ohm termination (figure), 4-9
    - receiving or driving MXIbus CLK10 (figure), 4-10
  - VXI-MXI-2/B module, 5-6 to 5-9
    - CLK10 generated from MXIbus (figure), 5-6
    - CLK10 generated from onboard oscillator (figure), 5-6
    - CLK10 generated from SMB (figure), 5-6
    - drive inverted external CLK SMB (figure), 5-8
    - drive non-inverted external CLK SMB (figure), 5-8
    - receive external CLK SMB (figure), 5-8
    - receive external CLK SMB with 50 ohm termination (figure), 5-8
    - receiving or driving MXIbus CLK10 (figure), 5-9
- VXIbus local bus configuration
  - VXI-MXI-2 module, 4-16 to 4-17
  - VXI-MXI-2/B module, 5-14 to 5-15
- VXIbus logical address. *See* logical address.

- VXIbus Slot 0/non-Slot 0 configuration
  - VXI-MXI-2 module, 3-5 to 3-6
  - VXI-MXI-2/B module, 5-4 to 5-5
- VXI-MXI-2 module
  - configuration, 4-1 to 4-17
    - configuration EEPROM, 4-12 to 4-14
    - front panel features, 4-3
    - MXIbus termination, 4-11 to 4-12
    - onboard DRAM, 4-14 to 4-16
      - DRAM configurations (table), 4-15 to 4-16
      - SIMM size configuration (figure), 4-15
    - removing metal enclosure, 4-3
    - right-side cover (figure), 4-2
    - trigger input termination, 4-10 to 4-11
  - VXIbus CLK10 routing, 4-6 to 4-10
    - CLK10 generated from MXIbus (figure), 4-7
    - CLK10 generated from onboard oscillator (figure), 4-7
    - CLK10 generated from SMB (figure), 4-7
    - drive inverted external CLK SMB (figure), 4-9
    - drive non-inverted external CLK SMB (figure), 4-9
    - receive external CLK SMB (figure), 4-9
    - receive external CLK SMB with 50 ohm termination (figure), 4-9
    - receiving or driving MXIbus CLK10 (figure), 4-10
  - VXIbus local bus, 4-16 to 4-17
  - VXIbus logical address, 4-3 to 4-5
    - selection (figure), 4-5
  - VXIbus Slot 0/non-Slot 0, 3-5 to 3-6
    - connecting MXIbus cable, 4-19 to 4-20
    - difference from VXI-MXI-2/B (note), 1-4
    - hardware description, 1-3 to 1-5
    - installation, 4-18
    - specifications
      - electrical, A-10
      - environmental, A-9
      - MXIbus capability descriptions, A-7
      - performance, A-10
      - physical, A-9 to A-10
      - requirements, A-9
      - VMEbus capability codes, A-8
- VXI-MXI-2/B module
  - configuration, 5-1 to 5-15
    - configuration EEPROM, 5-11 to 5-12
    - front panel features, 5-3
    - MXIbus termination, 5-9 to 5-10
    - onboard DRAM, 5-12 to 5-14
      - DRAM configurations (table), 5-13 to 5-14
      - SIMM size configuration (figure), 5-13
    - parts locator diagram, 5-2
    - trigger input termination, 5-9
  - VXIbus CLK10 routing, 5-6 to 5-9
    - CLK10 generated from MXIbus (figure), 5-6
    - CLK10 generated from onboard oscillator (figure), 5-6
    - CLK10 generated from SMB (figure), 5-6
    - drive inverted external CLK SMB (figure), 5-8
    - drive non-inverted external CLK SMB (figure), 5-8
    - receive external CLK SMB (figure), 5-8
    - receive external CLK SMB with 50 ohm termination (figure), 5-8

- receiving or driving MXIbus  
CLK10 (figure), 5-9
- VXIbus local bus, 5-14 to 5-15
- VXIbus logical address, 5-3 to 5-4
  - selection (figure), 5-4
- VXIbus Slot 0/Non-Slot 0, 5-4 to 5-5
- connecting MXIbus cable, 5-16 to 5-17
- difference from VXI-MXI-2 (note), 1-4
- installation, 5-15 to 5-16
- VXI*plug&play* standard, C-1